

# **Holy Name High School Wind Feasibility Study**

An Interactive Qualifying Project Report:

Submitted to the Faculty

Of the

WORCESTER POLYTECHNIC INSTITUTE

In partial fulfillment of the requirements for the

Degree of Bachelor of Science

By

---

Hans Erik Jensen

---

Brian Foley

---

Tyler Forbes

---

Adam Young

Date: September 22, 2006

Advisor: Professor Alexander Emanuel

## Table of Contents

Table of Figures .....	4
1. Abstract .....	6
2. Executive Summary .....	7
3. National Energy Situation .....	15
4. History of Wind Power .....	17
5. Wind Power Technology .....	20
5.1. The Power of Wind .....	20
5.2. Major Components of a Wind Turbine .....	27
5.2.1. Rotor .....	27
5.2.2. Transmission (Mechanical) .....	29
5.2.3. Generator .....	30
5.2.4. Tower .....	33
5.3. How do Wind Turbines Work? .....	36
5.3.1. Operating Characteristics .....	36
5.4. The life of a Turbine .....	39
5.4.1. Turbine Construction .....	39
5.4.2. Grid Interconnection .....	41
5.4.3. Maintenance and System Life .....	42
5.4.4. Health and Safety Issues .....	43
5.4.5. Environmental Impacts .....	46
6. Holy Name Background .....	48
7. Feasibility Study .....	50
7.1. Site Assessment .....	50
7.1.1. Meteorological Tower .....	51
7.1.1.1. Published Wind Data .....	63
7.1.1.2. Collected Wind Data .....	67
7.1.2. Land Area .....	69
7.1.2.1. Boundaries .....	70
7.1.2.2. Utility Line Locations .....	71
7.1.2.3. Distance from Neighboring Houses .....	73
7.1.2.4. Currently Used Land .....	74
7.1.2.5. Elevation .....	76
7.1.2.6. Grid Interconnection .....	77
7.1.2.7. Environmental Impact .....	77
7.1.2.8. Conclusions .....	77
7.1.3. Holy Name Electricity Usage .....	79
7.2. Economics .....	81
7.2.1. Turbine Selection .....	81
7.2.2. Expected Generation Profile versus Holy Name Load Profile .....	86
7.2.3. Financing .....	89
7.2.4. Net Metering .....	94
7.2.5. Energy Certificates .....	96
7.2.6. Tax Incentives .....	99
7.2.7. Economic Model .....	100
8. Project Achievements .....	105

9.	Project Conclusions .....	108
10.	References.....	110
11.	Resources.....	113
12.	Appendices.....	114
12.1.	Appendix A: Dimensional Analysis of Chimney .....	114
12.2.	Appendix B: Tower Design .....	115
12.3.	Appendix C: Weather Wizard III Data Sheet .....	116
12.4.	Appendix D: Published Wind Data and Wind Rose by AWS TrueWind.....	118
12.5.	Appendix E: Holy Name High School Property Topographical Map .....	120
12.6.	Appendix F: Wind Turbine Spec Sheets.....	121
12.7.	Appendix G: Monthly Weibull Distribution from Holy Name High School .....	127

## Table of Figures

Figure 1: Projected Turbine Output versus Holy Name Usage .....	9
Figure 2: Aerial photo depicting the most viable area of property for a wind turbine .....	11
Figure 3: Sources of generated electricity in North America [2].....	15
Figure 4: Brush's Windmill in Cleveland, Ohio [6].....	17
Figure 5: Smidth's Two Bladed DC Turbine [8].....	18
Figure 6: Juul's First Wind Turbine [9] .....	19
Figure 7: Wind Turbine Wind Flow Effects [10] .....	22
Figure 8: Mounted and Handheld Anemometers [10] .....	23
Figure 9: Sample Wind Rose [11] .....	24
Figure 10: Vertical Axis Wind Turbine [12] .....	25
Figure 11: Horizontal Axis Turbine [13].....	26
Figure 12: Cross Section View of Typical Turbine Assembly [14] .....	27
Figure 13: Hub and Blades of a Turbine Rotor [15].....	27
Figure 14: Wind Turbine Transmission.....	29
Figure 15: Electric Generator.....	30
Figure 16: The Rotor of a Synchronous Generator.....	30
Figure 17: Asynchronous Generation Apparatus.....	31
Figure 18: Cage Rotor.....	31
Figure 19: Lattice Tower [16].....	34
Figure 20: Monopole Tower [17] .....	34
Figure 21: Traditional Tube Tower [18].....	35
Figure 22: Turbine Construction Process [19].....	40
Figure 23: Existing concrete and brick chimney atop Holy Name (4' x 4' x 5') .....	53
Figure 24: Satellite dish mounted on cinder block platform atop Holy Name .....	54
Figure 25: Wooden Jig Constructed, Corner Bracket Being Welded.....	56
Figure 26: Close Up of Corner Bracket with Supporting Pole Tacked in Place.....	56
Figure 27: Close Up of Supporting Pole Connection .....	57
Figure 28: Tower Completed and Ready for Paint .....	57
Figure 29: Copper Electrode and Weather Station Affixed.....	59
Figure 30: Lightning Protection Connection to Existing System .....	59
Figure 31: Anemometer and Wind Vane .....	60
Figure 32: Corner Bracket and Braces Being Installed .....	61
Figure 33: Guy Wire Turnbuckle Connection .....	61
Figure 34: Weather Station Mounted in Closet .....	62
Figure 35: Tower Fully Installed .....	62
Figure 36: Published Wind Rose [29].....	66
Figure 37: Wind Speed Calculations at Different Height.....	67
Figure 38: Average Wind Speed per Month.....	68
Figure 39: Property Owned by Holy Name (red area is owned by others).....	70
Figure 40: Available Land for Turbine with Property Line Restrictions.....	71
Figure 41: Existing Utility Lines and Easement.....	72
Figure 42: Available Turbine Land with Property Line and Utility Line Restrictions.....	73
Figure 43: Property Line, Utility Line, and Neighboring Dwellings Restrictions.....	74
Figure 44: Existing Structures and Used Land .....	75

Figure 45: Available Land with Restrictions .....	76
Figure 46: Proposed Turbine Site .....	78
Figure 47: Average Electricity Usage by Month .....	79
Figure 48: Holy Name Electricity Bill Amounts .....	80
Figure 49: Holy Name Electricity Usage.....	80
Figure 50: FL600 50m Power Output Curve .....	85
Figure 51: Weibull Distribution by Season .....	87
Figure 52: Projected Turbine Output .....	87
Figure 53: Projected Turbine Output versus Holy Name Usage .....	88
Figure 54: Average Cost per kW of Rated Output [30].....	89
Figure 55: Breakdown of Renewable Energy Attributes.....	96
Figure 56: Projected Electricity Cost.....	101
Figure 57: Electricity Purchased and Sold.....	101

### **Table of Tables**

Table 1: Prevailing Wind Directions .....	20
Table 2: Decision Matrix for Anemometer Location .....	52
Table 3: Published Average Wind Speeds by Height and Season [29] .....	64
Table 4: Published Average Wind Speeds by Direction [29] .....	65
Table 5: Turbine Model Comparisons .....	82
Table 6: Turbine Model Output and Capacity Factor .....	84
Table 7: Loan Options for Holy Name with an FL600.....	92
Table 8: DOER percentage requirements for renewables [37].....	97
Table 9: Electricity Bill Analysis and Average Usage and Production Numbers .....	100
Table 10: 20 Year Cost Analysis .....	103

## **1. Abstract**

In the next few years, the rising cost of electrical energy will force Holy Name Central Catholic Jr./Sr. High School to make some difficult financial decisions that will affect the future of the institution. From August 2004 to August 2005, the school spent \$127,000 on electric energy, most of which was used to heat the building via a base-board electric heating system. This constitutes a sizable portion of the school's annual budget and as the price per kilo-watt hour (kWh) of electricity increases, it will translate into thousands of additional dollars spent on heating the building each year.

To avoid this predicament, Holy Name has decided to investigate the on-site generation of electricity via wind power. The installation of a wind turbine on their property would dramatically reduce the annual cost of heating their buildings with electricity. The savings would enable the school to improve the education offered to its students in several ways, including more academic opportunities and the latest technology. If the school is unable to secure the installation a wind turbine, Holy Name will be forced cut extracurricular and academic programs in order to cover their heating costs.

Therefore, it is the objective of this IQP to help facilitate the eventual construction of a wind turbine at Holy Name High School. A feasibility study based upon the economic and social issues surrounding such a project will be presented, as well as documentation of the additional steps taken by the group regarding conferences, meetings and presentations to help secure a wind turbine for Holy Name.

## 2. Executive Summary

In the next few years, the rising cost of electrical energy will force Holy Name Central Catholic Jr./Sr. High School in Worcester, Massachusetts, to make some difficult financial decisions that will affect the future of the institution. From August 2004 to August 2005, the school spent \$127,000 on electric energy, largely due to the base-board electric heating system. As the price per kilo-watt hour (kWh) of electricity increases, it will translate into tens of thousands of additional dollars spent on heating the building each year. To cover these added expenditures, the school's administrative board will need to decide from where the necessary funds will be drawn. Possibilities may include an increase in tuition and/or enrollment, termination of teaching positions, and cuts to extracurricular programs. While these steps may provide financial solutions in the short term, the long term implication could be as drastic as the eventual closure of Holy Name High School.

In the late 1990's and early 2000's, the school performed an exhaustive search of potential solutions to their energy crisis, including adding a computerized energy management system and the complete replacement of the current heating system. The computer control option was implemented, but the benefits were found to be insignificant. The replacement of the current system was deemed economically unreasonable because of the presence of embedded asbestos.

Last year, the Holy Name administration decided to investigate on-site generation of electricity via wind power. WPI was invited to implement the preliminary study to determine the feasibility of a wind power solution. To accomplish the goal, an engineering study, carried by this IQP team, was performed. The following areas were investigated:

- Wind potential,
- Economics,

- Interfacing with the Electrical Utility,
- Ecological and Social Impacts.

The feasibility study came out in favor of a wind turbine installation and steps were taken to advance the project to the phase of implementation.

The WPI team began by researching the theory behind wind power and the installation of wind turbines. Particular areas of interest included wind patterns and the necessary requirements for electric generation, turbine design and energy conversion, site preparation and tower construction, economics and associated costs, as well as social and environmental concerns. Various methods of research were used, including visits to a recently installed wind turbine, attending an alternative energy conference, meetings with wind power consultants, and a variety of on-line sources pertaining to wind power around the world. The information gathered from the sources enabled us to (a) identify the criteria necessary to determine if wind power would be a viable solution to the problem, and (b) formulate a plan for exploring these criteria.

When considering the installation of a wind turbine, there are two predominant areas of concern:

- 1) The economic feasibility of installing a wind turbine.
- 2) Fulfillment of local, state and federal regulations regarding the construction and operation of a wind turbine.

Complete and accurate assessments of these requirements are critical in determining the overall feasibility of the project.

The economics of the project were evaluated by creating a mathematical model. The model takes in the installation costs, grants, loans, projected electricity generated by the turbine, electricity usage by Holy Name, and green-energy credit programs. The model outputs the



payback period, total project cost over 20 years, yearly electricity payments, and average price per kilo-watt-hour over a twenty year period. The projected electricity generated from the turbine was calculated using a statistical model based on a Weibull distribution.

Based on the mathematical model, a 600 kW wind turbine would be the best fit for Holy Name. In Figure 1, a turbine of this size would produce 60-70% of the school’s electricity during the peak demand periods in the winter months.

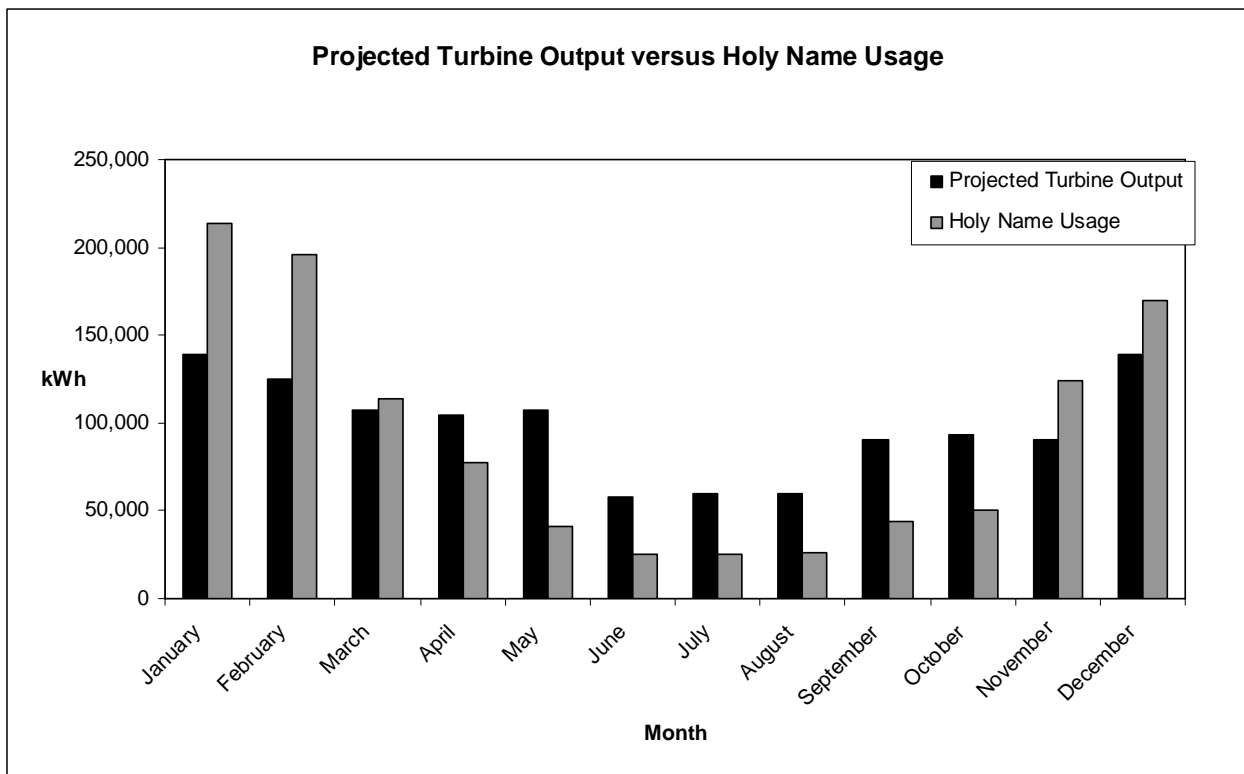

**Figure 1: Projected Turbine Output versus Holy Name Usage**

Given an installation cost of \$1.4 million for the turbine, plus operating costs, minus the amount of money received from grants and renewable energy certificates, the result obtained from the model would be a payback period of 5 to 7 years. Over a 20 year period, the school would pay as little as \$0.011/kWh for their electricity.

The initial weather data used in the Weibull distribution was taken from an online wind-mapping site. Concern regarding the accuracy of the online information led to the need to gather measurements of average wind speed and direction at Holy Name. With the permission of the Headmaster, Mrs. Mary Riordan, a guyed, welded steel tower was constructed and installed atop an old smokestack on the school. Mounted to this tower is an anemometer that measures wind speed and direction every ten minutes and stores the readings on a computer inside the school. The data is downloaded on a weekly basis and imported into excel where it can be extrapolated to the heights appropriate for wind turbines. The anemometer has been gathering data since Mid-December, 2005 and the results obtained thus far confirm the validity of the average wind speeds available online.

The investigation of the legal requirements regarding the installation began by researching the primary areas of concern at the local, state and federal levels. From the research, the necessary steps to gain approval for the construction of a wind turbine were identified. These steps included:

- 1) The application for a building permit from the local government,
- 2) The request for a grid-interconnection assessment from the respective power company,
- 3) An obstruction evaluation performed by the Federal Aviation Administration (FAA).

Having identified these steps, more information was gathered by interviewing individuals who have put up wind turbines and dealt with building permits, grid-interconnection studies, and FAA studies. One such resource was Brother Joseph Byron from the Portsmouth Abbey School in Portsmouth, RI.

From the information gathered via these sources, our team was able to narrow down the possible locations for a turbine. To determine the appropriate location, a thorough assessment of

the terrain and property at the school was performed. Using topographical maps, site survey information and aerial photographs, the zoning regulations regarding set-backs from property lines, line-of-sight considerations with adjacent property, noise pollution, and site access for construction vehicles were studied. The survey also took into account the interconnection of the turbine into the existing power network, encouraging a location close to an existing power line in order to minimize the need for additional wiring. Figure 2 is an aerial photo of Holy Name's property. The x near the center of the photo is the most suitable area for the school to install their turbine.

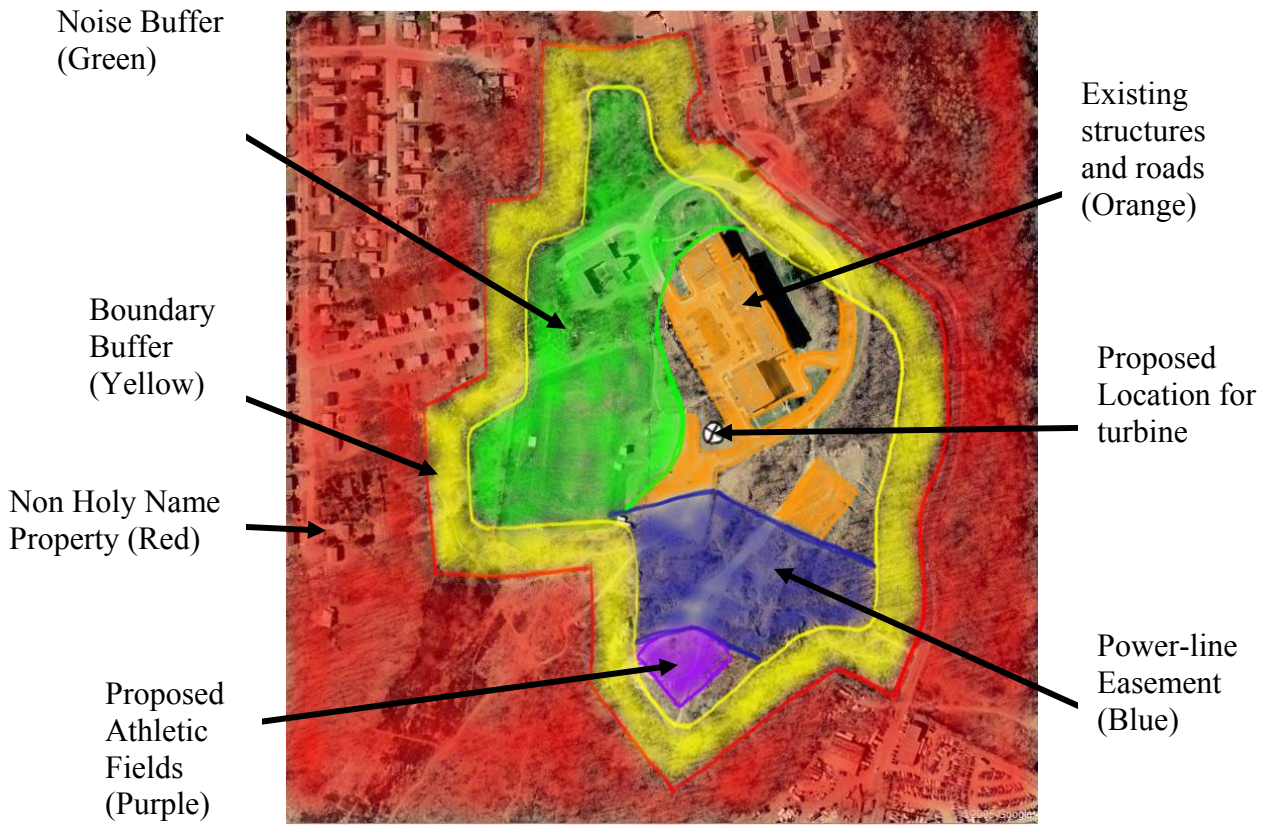

**Figure 2: Aerial photo depicting the most viable area of property for a wind turbine**

In addition to the land area assessment, the process for gaining approval from the FAA was researched. After participating in a conference call with a representative from the FAA, it

was our responsibility to file obstruction evaluations for three specific sites on the school's property. The coordinates of these three locations, along with the necessary information regarding the specific turbines that were selected, was submitted electronically on the FAA website.

It was determined that the installation of a 600kW wind turbine at Holy Name is feasible.

The conclusion was reached based upon the following information:

- 1) The school's demand for electricity,
- 2) Experimental verification for the availability of sufficient wind speeds on site,
- 3) The favorable economics.

The recommendation is for the school to install a 600 kW turbine atop a 50 meter (approx. 164 ft) tower. Such a turbine would produce 60-70% of the school's electricity during the peak demand periods in the winter months. The payback period of the turbine would be 5 to 7 years. If the school does not install a wind turbine, they will be faced with an estimated \$4.5 million electricity bill after 20 years. By installing a wind turbine, over a 20 year period, Holy Name will spend only \$300,000 on electricity and the turbine. Furthermore, a list has been compiled of suggested installation sites on Holy Name's property where a wind turbine could be erected.

As energy prices are predicted to increase annually, Holy Name is in desperate need of a viable solution to the problem that they are faced with. The installation of a wind turbine on their property would dramatically reduce the annual cost of heating their buildings with electricity. The savings would enable the school to improve the education offered to its students in several ways, including increased academic opportunities, and the latest technology being implemented into the classroom.

Beyond the benefits to the school, a wind turbine in Worcester, MA would serve as a landmark of change. As we march onward into the next century, we are already faced with an impending energy crisis. The implementation of wind power and other renewable sources of energy are extremely important if we as a society are intent upon maintaining our everyday lives as we know them.

The major events that marked the progress of this project are summarized on the following page. The block diagram highlights the work done to pave the road toward the implementation of a 600kW wind turbine, the first wind turbine in Worcester County.



### 3. National Energy Situation

As the population of the world continues to grow and more developing countries are moving towards an industrial economy, the consumption of petroleum based fuels is also increasing. According to a recent release by the Energy Information Administration (EIA), it is predicted that the total demand for domestic energy consumption will increase by 1.4 percent annually in both 2006 and 2007 [1]. As the demand for energy increases, the energy produced by various sources will exhibit an increase in value and subsequently cost the consumer more money.

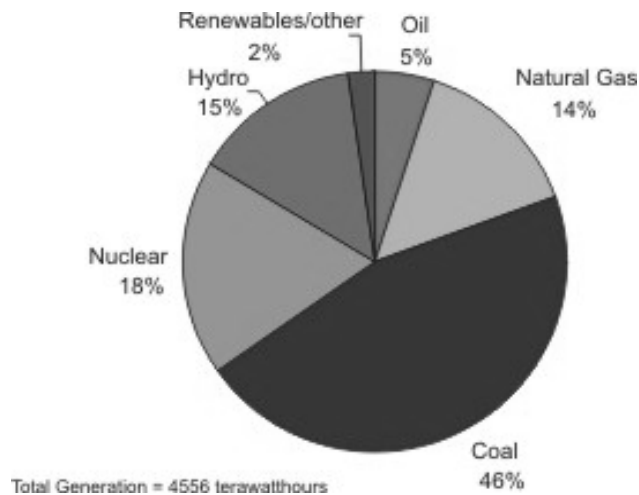

**Figure 3: Sources of generated electricity in North America [2]**

Most of the electricity generated in North America is done so by burning fossil fuels (oil, natural gas, and coal: see Figure 3). The heat given off in the combustion process is used to make steam that can then be used to spin the turbine generators that produce electricity. As we can see in Figure 3, coal is by far the most common source of generated electricity, accounting for 46% of the total amount produced [2]. In fact, approximately 90% of the coal mined in North America is used for the production of electricity [3].

Though coal is a fairly abundant fossil fuel within our continent, there are a number of environmental issues pertaining to its use. Until the 1960s and 1970s, there were very few environmental restrictions in place for coal power plants to follow. However, due to the growing concerns surrounding acid rain (sulfur-dioxide) and the sizable emissions of carbon dioxide contributing to the greenhouse effect, the Federal Government intervened with the Clean Air Act and the Clear Water Act to help reduce the amount of pollution expelled into the environment [4].

Since then, the energy industry has been continually researching new ways to reduce the amount of harmful compounds produced by their power plants and other facilities. However, the development and implementation of these solutions cost a great deal of money. Therefore, as the demand for electricity continues to rise and tighter constraints are placed upon the emission of coal-based generation facilities, the price of electricity will also increase. Based on market trends, the average cost of electricity to a commercial consumer in New England is expected to increase from 12.0 cents per kilowatt hour (kWh) in 2005 to 12.5 cents per kWh in 2006 and 12.8 cents per kWh in 2007 [5].



## 4. History of Wind Power

Since ancient times, man has harnessed the power of the wind for a variety of tasks. Some ancient civilizations, like the Persians (500-900A.D.), used the wind to grind grain into flour, while others used the wind to transport armies and goods across the ocean and other bodies of water. More recently, mankind has used the power of the wind to pump water and produce electricity.

The first man to harness the power of the wind to produce electricity was Charles F. Brush [6]. Brush was the owner of Brush Electric in Cleveland Ohio and in 1887 he created the first automatically operating wind turbine. Brush's turbine was very large compared to other wind mills of the time period. His turbine stood about 75ft tall with a rotor diameter of 50ft and consisting of 144 blades made from cedar wood (Figure 4). The output from Brush's creation was only about 12kW, but he ran the turbine for 20 years and used it to charge batteries in the basement of his mansion.

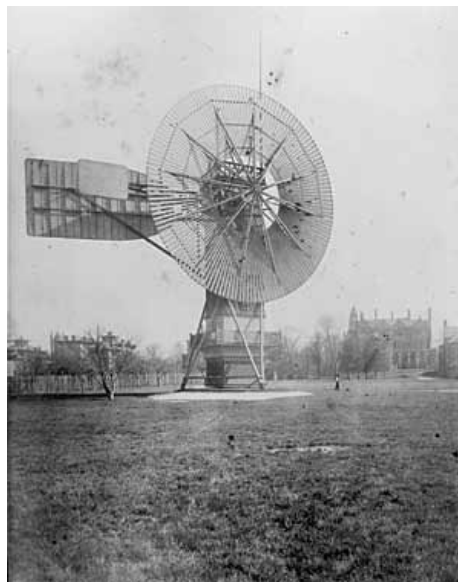

**Figure 4: Brush's Windmill in Cleveland, Ohio [6]**

Poul la Cour is considered the pioneer of modern electricity generating wind turbines in Denmark because of his vast contributions to the basic principles that govern modern wind turbines [7]. Cour was originally trained to be a meteorologist and brought this background, along with knowledge of modern aerodynamics, into the field of wind turbines. He built two wind turbines at the Askov Folk High School in Askov, Denmark in 1897. Cour used the wind turbines to generate electricity and produce hydrogen to be used for the school lights. He was the founder of the Society of Wind Electricians in 1905 and published the first journal on wind power; the Journal of Wind Electricity.

The next leap forward in the wind power industry occurred in Denmark during World War II by a company called F.L. Smidth Turbines. Smidth Turbines began producing two and three bladed turbines that produced a DC voltage. In 1951, they replaced one of their DC turbines with a 35kW AC generator, making the wind turbine the second in the world to produce AC. Figure 5 shows a photograph of one of Smidth's two bladed turbines that produced DC.



**Figure 5: Smidth's Two Bladed DC Turbine [8]**

Johannes Juul will always be remembered as the man who pioneered the development of the AC generating wind turbines [9]. Juul's background in wind power came from being one of Poul la Cour's "Wind Electricians." Juul built a 200kW turbine for SEAS Power Company in southern Denmark in 1956. His wind turbines were very advanced (at the time) and included electromechanical yawing and aerodynamic tip brakes. His first wind turbine ran for 11 years without any maintenance. Figure 6 shows a drawing of Juul's first wind turbine with advanced features.

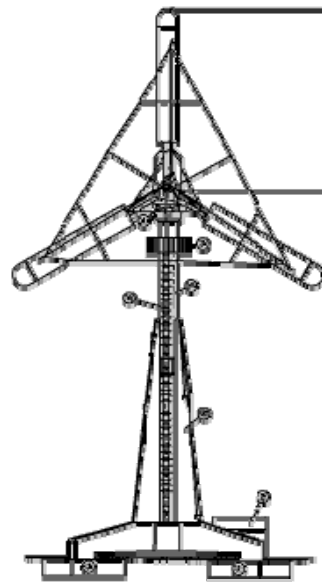

**Figure 6: Juul's First Wind Turbine [9]**

During the next 4 decades, wind turbines were produced using the basics set forth by Brush, Cour, Smidth, and Juul. As the years went by, the turbines became more efficient, quieter, safer, and more reliable due to technological improvements.

## 5. Wind Power Technology

### 5.1. *The Power of Wind*

There are many different types of air flow that can be observed. Some are useful to the wind power industry; others are not useful at all. The winds that influences weather the most are called Global winds or Geostrophic winds. Global winds are caused by the cyclic heating and cooling of the earth and the associated pressure differences. Most of the heat on earth exists near the equator. Air near the equator is warmer than the air at either pole. The difference in temperature creates a difference in pressure and winds that move North and South from the equator towards the poles are created daily. When this mass of warmer air tries to move north and south, an interesting phenomenon occurs, called the Coriolis force. The Coriolis force is caused by the rotation of the earth. The result of the rotation is a bending of the air mass towards the right or left depending which hemisphere is observed. The Coriolis force stops the air jet from going any further than 30 degrees latitude North and South. The Coriolis force is the cause for the Prevailing Wind Direction. Table 1 highlights the prevailing wind directions. Another interesting fact about global winds is that they aren't affected by the surface of the earth. Global winds are found about 3300ft above ground. The global winds are measured using weather balloons that record the data and transmit it back to earth.

**Table 1: Prevailing Wind Directions**

Latitude	90-60N	60-30N	30-0N	0-30S	30-60S	60-90S
Direction	NE	SW	NE	SE	NW	SE

Surface winds are the winds up to 330ft above ground. There a few different types of surface winds, ranging from sea breezes to mountain winds. Sea breezes take place where the

ocean meets land. During the day, the land heats up much quicker than the ocean, causing a low pressure area to occur over the land mass. The cooler air over the ocean rushes into the land creating a breeze. During the evening and night, the opposite occurs but on a small scale because the sea heats up and cools down much slower than land, so the winds are gradual. Mountain Ranges have different types of surface winds. Valley winds are very common in mountainous areas because large south facing slopes. During the day, the air rushed up the slope towards the top of mountain and then during the evening and nighttime, the air rushes back down the slope into the valley. Another mountain type wind is canyon winds which can race up and down canyons or long slightly sloped valleys. All of the surface-type winds are useful in producing electricity using wind turbines.

Extracting energy from the wind is a precise science. The amount of energy transferred to a rotor of a wind turbine is a function of the wind speed, the air density, and the rotor area. The faster the air is moving, the faster the blades on the turbine will spin, increasing the energy produced. Heavier or denser air has more potential to extract power from the wind because denser air can move the turbine blades more effectively. Lastly, to a certain point, the larger the rotor area, the more wind that will be utilized by the turbine, thus more energy production. The kinetic energy of a moving body is proportional to its mass. In terms of wind, the kinetic energy in the wind depends on the density of the air or it's mass per unit volume.

When a wind turbine is erected, the formulas for calculating the amount of power the wind will produce become more complicated because wind turbines deflect the wind. As seen in the diagram, the wind enters the turbine at one speed (V1), and leaves the turbine with a slower speed (V2). The reason for this is that the rotor blades slow down the air as it enters the turbine.

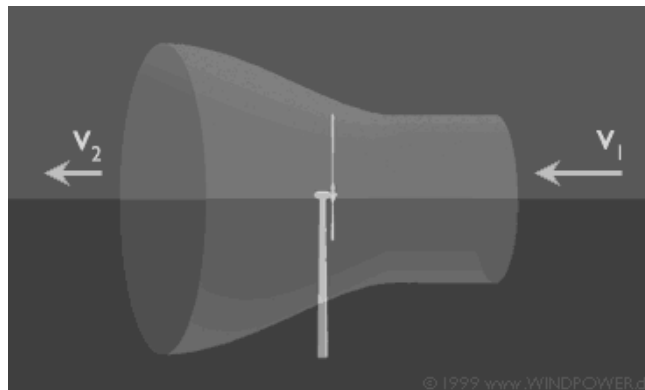

**Figure 7: Wind Turbine Wind Flow Effects [10]**

When the air leaves the turbine, it is slower than initial so it takes up a larger area. (See Figure 7) Further down the stream, the slow air mixes with the faster moving air, creating turbulence and ultimately returning to the initial speed. Betz's Law states that less than 59% of the kinetic energy in the wind can be converted to mechanical energy using a wind turbine.

The energy content of the wind varies with the cube of the average wind speed. If the speed of the wind is doubled, then the wind would have 8 times the amount of energy. This is analogous to doubling the speed of a car and the energy required to have it brake to a stop. This concept is demonstrating Newton's second law of Motion. The power that the wind possesses can be demonstrated using the following formula:

$$P = \frac{1}{2} \rho v^3 \Pi r^2$$

**Equation 1: Power of the Wind**

P equals the power of the wind in W,  $\rho$  is the density of dry air in  $\text{kg/m}^3$ , v is the velocity of the wind in m/s, and r is the radius of the rotor in meters.

Measuring wind velocity and direction is one of the most critical preliminary steps to the successful installation of a wind turbine. Wind is measured with a device called an anemometer. A photo of a handheld anemometer and a mounted anemometer can be seen in Figure 8. If anemometers are to be fitted onto a mast, they should be fitted to the prevailing wind side, or better yet, placed on top of the mast to minimize wind disturbance caused by the mast. The standard for wind speed recording is once every 10 minutes (10 minute intervals). Today there are available data loggers that transmit the data wirelessly. The reason for this standard is simple. Software packages that are used to analyze the data, produce wind roses, and other useful information, need to receive the raw data in a certain way. Thus, software companies can design software to work on all anemometer packages.



**Figure 8: Mounted and Handheld Anemometers [10]**

Wind Roses (Figure 9) are useful tools for wind evaluations. A wind rose shows the direction and amount of wind in each direction. The wind rose is typically divided up into 12 sectors or 30 degree blocks of the horizon. The wind rose is also useful because it displays the relative frequency of each block, a normalized average wind speed for each sector, and the contribution of each block to the total energy of the wind.

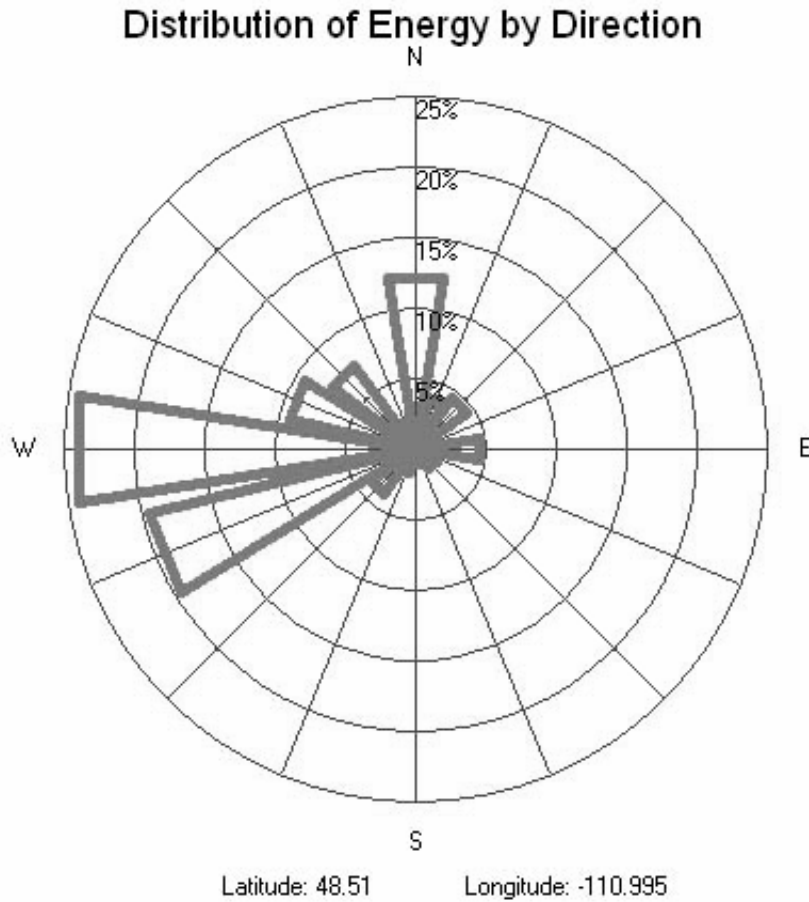

**Figure 9: Sample Wind Rose [11]**

The wind rose in Figure 9 shows the percentage of the wind for each direction. It shows that 25% of the wind in that location comes from the west.



## Types of Wind Turbines

Before the specifics of turbine design are examined, let us consider the two general categories of wind power technologies. These categories are Vertical-Axis Systems and Horizontal-Axis Systems, each of which encompasses their own benefits and detriments compared with the other.



**Figure 10: Vertical Axis Wind Turbine [12]**

The Vertical-Axis turbine (Figure 10) operates exactly as its name would suggest. In this design, the axis of rotation is oriented vertically, perpendicular to the surface of the earth. One of the major benefits of such a design is that it is able to operate at maximum efficiency no matter which direction the wind is coming from. Examples of vertical-axis turbines include the Savonius machine, the Giromill and the 500 kW Darrieus “egg-beater” machine operated by the Department of Energy.



**Figure 11: Horizontal Axis Turbine [13]**

Horizontal-Axis turbines (Figure 11) have an axis of rotation parallel to the ground, pointed either into the oncoming wind flow (upwind) or with the direction of the wind (downwind). To take advantage of the increased wind speeds at higher altitudes above the earth's surface (as well as to provide clearance between the rotor blades and the ground), horizontal-axis turbines are often mounted on top of a tall tower. Vertical systems are very difficult, if not impossible to mount atop towers, relegating them to the slower, sometimes turbulent winds closer to the ground. This is a major benefit of the horizontal systems over the vertical ones, often making them much more productive for any given location.

However, unlike vertical-axis systems that operate at maximum efficiency for any wind direction, horizontal-axis turbines require an additional “steering” or yaw mechanism to keep the turbine tracked directly into or with the wind. As the direction of the wind fluctuates even a few degrees, a wind vane sensor and control system trims the yaw of turbine so that the rotor can extract the maximum amount of energy from the wind. Such systems add complication and cost to the overall turbine package, increasing both the initial and maintenance costs for the horizontal turbines over the vertical ones.

## 5.2. Major Components of a Wind Turbine

Of the many wind turbine models found around the world, most operate in a similar way and have components that serve very similar functions. Figure 12 shows the major components that most wind turbines have inside of them.

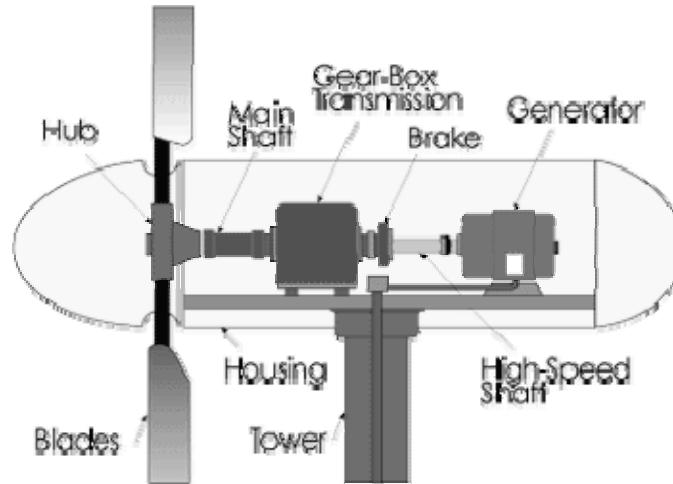

Figure 12: Cross Section View of Typical Turbine Assembly [14]

### 5.2.1. Rotor

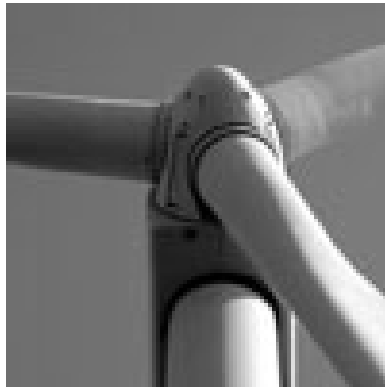

Figure 13: Hub and Blades of a Turbine Rotor [15]

The rotor (Figure 13) is the turbine component responsible for collecting the energy present in the wind and transforming that energy into mechanical motion. As the overall diameter of the rotor design increases, the amount of energy that the rotor may extract from the

wind increases as well. Therefore, turbines are often designed around a certain diameter rotor and the predicted energy that it may remove from the wind.

The predominant aerodynamic principles that rotor designs are based upon are Drag Design and Lift Design. Drag design rotors operate on the idea of the wind “pushing” the blades out of the way, thereby setting the rotor into motion. Drag design rotors have slower rotational speeds but high-torque capabilities, making them ideal for pumping applications. With Lift design rotors, the blades are designed to function like the wing of an airplane. Each blade is designed as an airfoil, creating lift as the wind moves past the blades. The airfoil operates on the basis of Bernoulli’s Principle where the shape of the blade causes a pressure differential between its upper and lower surfaces. This disparity in pressure causes an upward force that lifts the airfoil. In our case, this lift causes the rotor to rotate, once again transforming the energy in the wind into mechanical motion.

The design of the individual blades also affects the overall design of the rotor. Since the blades require a fairly smooth airflow to perform properly, the blades must be arranged around the axis of rotation so that they cause the minimum amount of turbulence to the airflow of adjacent blades. It is for this reason that most rotors have only two or three blades.

### 5.2.2. Transmission (Mechanical)

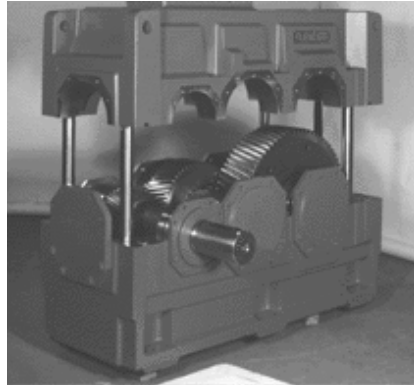
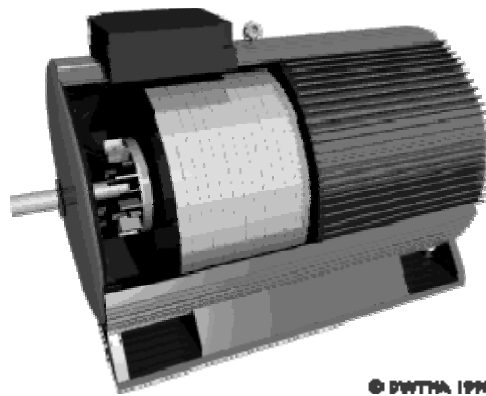

**Figure 14: Wind Turbine Transmission**

Due to their huge diameters, the rotors of large scale wind turbines tend to have slower rotational speeds. In most cases, these speeds are insufficient to operate their generators at peak efficiency (for most generators, somewhere between 1200-1800 revolutions per minute (rpm)). The solution is to insert a gear-box transmission between the rotor output shaft and the generator input shaft so that that rotor speed can be geared up to the appropriate rpm for maximum power generation.

Wind turbines with smaller rotor diameters may not need a transmission between the rotor and generator. A decrease in rotor diameter results in a smaller arc-length that the rotor must travel per revolution, ultimately causing a comparatively larger rotational speed than that of a larger rotor for a given wind speed. If these larger rotational speeds are appropriate for the type of generator being used, the rotor may be connected directly to the generator resulting in a Direct-Drive system. These systems tend to be simpler and require less maintenance; however they require a larger generator in order to produce voltages comparable to that of AC power. Therefore, Direct-Drive systems are predominately used in DC applications (Battery charging, etc).

### 5.2.3. Generator



**Figure 15: Electric Generator**

The generator is the component of the wind turbine responsible for converting the mechanical motion of the rotor into electrical energy. There are many different types and sizes of electric generators for a wide range of applications. Depending on the size of the rotor and the amount of mechanical energy removed from the wind, a generator may be chosen to produce either AC or DC voltage over a variety of power outputs.

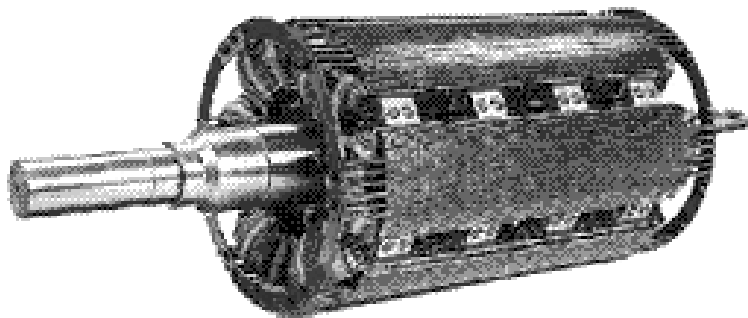

**Figure 16: The Rotor of a Synchronous Generator**

There are two main types of electrical generators for converting mechanical energy. The first is the Synchronous generator. The synchronous generator operates on the principle that as a magnet is rotated in the presence of a coil of wire, the changing magnetic field in space induces a current, and therefore a voltage in the coil of wire. In our case, the magnet is attached to the

input shaft of the generator and is surrounded by several coils of wire, individually referred to as a pole. As the shaft rotates, so does the permanent magnet which creates a changing magnetic field in the presence of the poles which surround it. This induces a current in each of these poles and electrical energy is produced. Synchronous generators are typically quite simple and can be used in a wide variety of applications.



**Figure 17: Asynchronous Generation Apparatus**



**Figure 18: Cage Rotor**

The second type is the Asynchronous generator. At the heart of this design is its cage rotor, which is essentially a cylindrical cage of copper or aluminum bars that concentrically surround an iron core. Once again, this rotor is surrounded by a series of poles on its periphery called the strator. One way in which the asynchronous generator varies from the synchronous

one is in that it is actually powered by the grid to set itself into motion initially. As the current from the grid passes through the stator, a current is induced in the cage rotor itself; causing opposing magnetic fields that set the rotor in motion at a specific rotational speed (this speed is determined by the frequency of the supply current and the number of poles in the stator). The generation of electricity occurs when the wind causes the rotational speed of the rotor to increase above this idle speed caused by the grid. What is fascinating about this phenomenon is that very large voltages can be produced for comparatively small increases in rotational speed (considerable voltage for 10-15 rpm increase). With the rotor already in motion, there is little torque applied to the rotor shaft, ultimately resulting in less wear on the transmission. However, the Asynchronous generator is much more complex than the synchronous one and also requires an initial source of power to operate. Asynchronous generators are more appropriate for applications where there is a fairly constant wind speed that rarely drops below a certain value. This way, the generator is consistently producing its maximum power since the rotor speed is above the idle speed. Synchronous generators are more appropriate in applications where the average wind speed may be appropriate; however there are times when the wind speed may dip far below the average for a sizeable period of time.

There are two major steps which characterize the generation process. The first is the actual conversion of the mechanical energy to electrical, for which we employ one of the generators mentioned previously. However, the raw output of these generators is highly irregular with voltages and frequencies that may vary tremendously and are referred to as being “wild” in nature. Therefore, we need a second step where the output from these generators is regulated to a fairly constant voltage and frequency before it may be utilized in any sort of an electrical application. To accomplish this, there are power processing devices that take the



generated output and produce a specific voltage and frequency. For example, to produce power that can be passed through the electrical grid here in the United States, we would require a regulation device that would output a 120V RMS AC voltage at a frequency of 60Hz.

#### **5.2.4. Tower**

One of the most important pieces of the wind turbine assembly is the tower that it is mounted upon. Mounting a wind turbine on the highest possible tower results in increased power production due to the stronger winds present at higher altitudes. In addition, the effects of the wind shear caused by the surrounding terrain is also much less at higher altitudes, providing yet another reason to mount the turbine as high as possible.

Of course, there are some limitations as to how tall of a tower is appropriate for a given application. One such consideration is the structural requirement necessary to support the turbine being considered, included how much the turbine weighs as well as what types of environmental forces (high winds, snow, rain) it will have to sustain over time. Zoning regulations may also play a role in dictating the maximum allowable height that the turbine assembly may be elevated off the ground.

There are many different types of towers available for a wide variety of turbine sizes. One of the primary categories is the Lattice Tower (Figure 19) which is essentially a very narrow, pyramid shaped structure that is strengthened with trusses. Towers of this variety may be self-supporting or they can be further supported by guy wires.



**Figure 19: Lattice Tower [16]**

The other predominant type of tower is the monopole tower (Figure 20). This type of tower consists of a single pole that supports the turbine. As we might expect, lattice towers are much sturdier and can therefore elevate wind turbines to much greater heights than the monopole tower. However, the lattice towers also require more ground space for their larger footprint than what is necessary for a monopole tower.

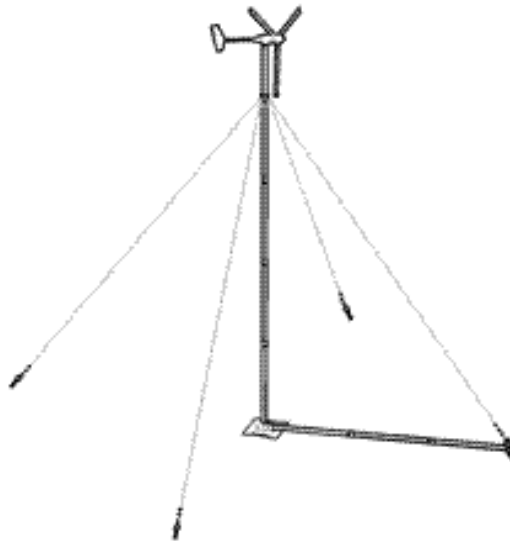

**Figure 20: Monopole Tower [17]**

As seen in the previous figures, there is seemingly a trade off between strength and the amount of land consumed by the tower. This was true up until the advent of the now traditional tube tower (Figure 21). As strong, if not stronger, than a lattice tower, the tube tower takes up not much more land than a monopole tower. Due to its immense foundation, located almost entirely underground, tube towers are extremely sturdy structures that can withstand the strongest forces. While not possible until today's modern manufacturing and engineering practices, tube towers have engulfed the entire wind industry and it is rare to see a turbine of any appreciable size erected that is not sited on a tube tower.



**Figure 21: Traditional Tube Tower [18]**

### **5.3. How do Wind Turbines Work?**

Wind turbines convert the kinetic energy of the fluid flow of the air (wind) into electrical energy. The turbine apparatus has two roles; (1) To extract the energy available in the wind's motion via mechanical means using a rotor, and (2) To convert this mechanical energy into electric energy that can be in turn converted into other forms of energy.

While the specific designs and pertinent components of a given turbine are likely to be quite different depending on the application, the key mechanisms in accomplishing the functional goals of the turbine are rather consistent. These mechanisms are the rotor and the generator, each of which is responsible for the conversion of energy from one form to another.

To gather the energy present in the wind, a rotor is used to translate the lateral motion of the moving air into rotational motion. The design of the rotor may vary a great deal from one application to the next, depending largely on the aerodynamic principles employed in its design, as well as upon the overall design of the wind system (Horizontal Axis versus Vertical Axis).

#### **5.3.1. Operating Characteristics**

While each turbine comes with its own myriad of operating specifications, there are a few that are of particular importance when considering the right turbine for a given application. The Cut-in, rated and Cut-out wind speeds of a particular turbine are of immense importance in determining which model is best suited for a specific location.

The Cut-in speed of a turbine is the minimum wind speed at which the rotor will turn fast enough to generate usable power. Due to the moment of inertia of the rotor, as well as the static forces within the turbine assembly, the wind must attain a nominal speed, the cut-in speed, to overcome these forces and set the turbine in motion. Once in motion, the rotor is supplying

mechanical energy to the generator and the turbine can begin to generate power. The value of the cut-in wind speed is typically somewhere between 7-10 mph (3-4.5 m/s) for most wind turbines. In most applications, the lower the value of the cut-in speed the better, since the turbine will be able to generate some sort of power even at the very lowest average wind speeds.

The Rated speed of the turbine is the minimum wind speed at which the generator will be able to produce its rated power. At wind speeds above this rated value, the output of the turbine levels off since the generator has already attained its rated output capability. Values for this characteristic typically range from 25-35 mph (11.2-15.5 m/s). Average wind speeds within this range would be ideal for generating maximum amounts of energy from a location. However, we often find that the average wind speed is much less than the lower bound of a turbine's rated wind speed, sometimes by as much as 10-15 mph.

The Cut-out speed of a given turbine is the wind speed at which the turbine mechanism will shut-down. When the wind speed exceeds this cut-out value, the turbine will begin to employ a series of protective measures to thwart the turbine from destroying itself. One such measure is a very simple mechanical break within the turbine assembly that attempts to slow the rotational speed of the rotor shaft via frictional forces. Other measures focus on the rotor blades to slow the system down. One such measure employs individual pitch control of each blade to decrease lift and slow the rotor, while another system, called the tip-break, makes a radical change to the orientation of the tips of the blades, causing a great deal of drag which also serves to slow the rotational speed of the turbine. Without these safety measures, the presence of a very strong wind could cause the destruction of the turbine and put nearby residents and property in great danger should the blades be ejected from the rotor, the tower fall over, etc. However, with

these systems in place, the turbine is able to survive these high winds and maintain the safety of those nearby.

The rotational motion of the rotor is transferred along a shaft that ultimately reaches a generator. The specific method with which the generator produces electricity varies from system to system, however the basic idea is that the generator transforms the mechanical motion of the rotor into electrical energy, thereby fulfilling the functional duty of the wind turbine.

## 5.4. *The life of a Turbine*

### 5.4.1. Turbine Construction

While wind turbines occupy less than one percent of the total area of a wind farm, much consideration must be given to the preparation of the installation site in order to insure a proper set up. The footprint of a wind turbine is actually quite small, approximately fifteen feet around, however, it extends deep down into the earth. A general rule is, for every ten feet of tower height, the concrete pier must be one foot deep. Thus, if the tower is six hundred feet in height, then the concrete pillar in the ground must be sixty to seventy feet deep. For example, to install the one hundred twenty foot Bergey 10kW tower, one must install three 36” diameter piers that are twenty feet deep. A five hundred pound cage of rebar must also be installed in each pier.

To prevent interference with its operation, the area surrounding the turbine must be kept clear of trees and brush. By some figures, roughly an acre must be cleared around each turbine to allow for its installation and the necessary peripheral components to be installed.

To run transmission lines, the ground must be dug up so that the lines can be laid beneath the earth or a trough of trees must be cut away so that transmission lines and poles can be installed. Also, access roads must be placed so that trucks and other assembly vehicles can reach the area to install and maintain the turbine. Figure 22 shows photo's from the construction of a 1.2MW Wind Turbine in Canada.



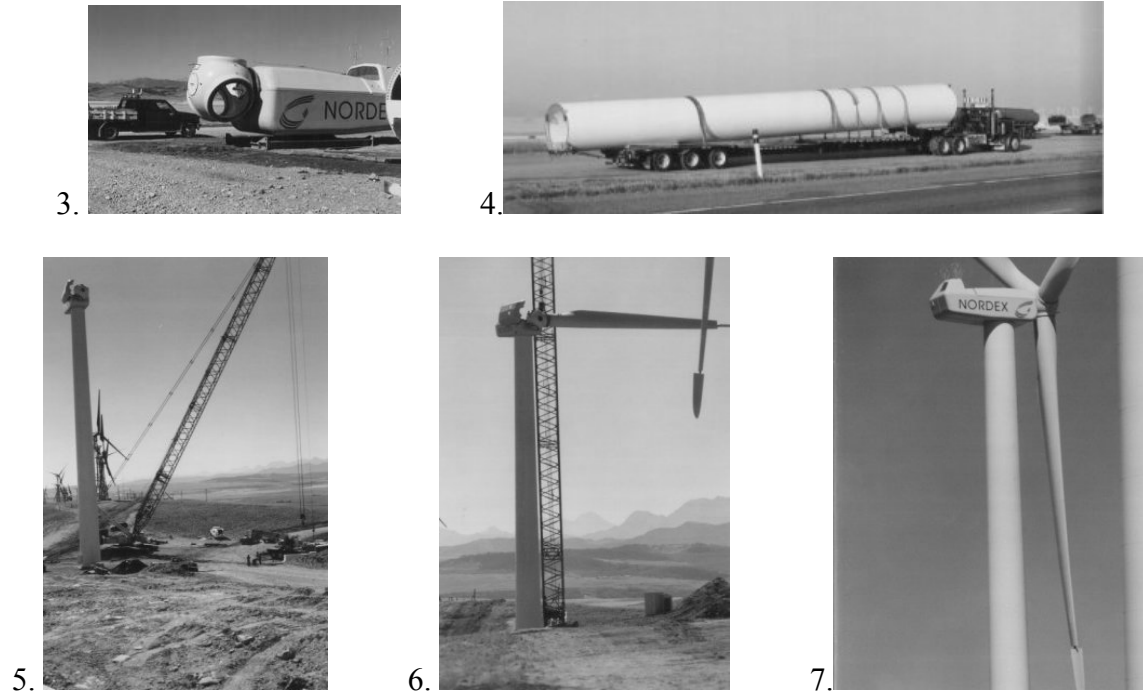

**Figure 22: Turbine Construction Process [19]**

1. Hole has been dug, first layer of concrete down, and rebar lattice in place
2. Foundation finished, with imbedded bolts exposed
- 3, 4. Hub and tower trucked to site
- 4, 5. Tower assembled in sections, hub attached to top, rotor blades installed



### **5.4.2. Grid Interconnection**

There are a few different options when connecting to the electric grid. One way is an indirect grid connection. An indirect grid connection is when the turbine outputs a variable AC voltage, depending on the speed at which the rotors are moving. The variable AC is output from the turbine and then rectified so the result is fluctuating DC. The conversion is usually done using thyristors or large power transistors. The next step is to convert the fluctuating DC back to fixed frequency AC that has a regulated sinusoidal output voltage. This process can also be done using thyristors or transistors. The output from the conversion to fixed AC still has spikes and sags, therefore filters are needed to shape the wave into the exact form the utility companies use. Filters are created using different combinations of inductances and capacitances. The advantages of an indirect grid connection is that it makes it possible to harness more of the winds power because now the full power of a gust of wind can be harnessed. Using this method also helps to relieve stress on the tower and rotor because peak torque is being used. Another advantage to using this method is that modern power electronics facilitates voltage phase shifting and the reactive power can be controlled easier. This condition helps improve the quality of power being added to the grid. The major disadvantages that come with indirect grid connections are cost and energy loss. The power electronics systems are expensive and the conversions from AC to DC to AC reduce the overall efficiency of the system leading to harmonic distortion of the AC current injected to the electrical grid.

Another option is to connect the generator output directly to the grid. This can be accomplished with turbines that employ asynchronous generators, when connected to a nearby, 3 phase AC power grid. In most cases however, this is not practical. Therefore, indirect grid connections are much more popular due to the feasibility of their installation.

### **5.4.3. Maintenance and System Life**

To keep the wind turbines operating at the peak of their potential, manufacturers strongly suggest that the entire system be completely checked on an annual basis. Not only does this check include the mechanical parts of the turbine assembly itself, but it also includes the tower and other support structures, as well as the wiring between the output of the turbine and wherever the power is being routed. Some of the specific tasks within these and other areas include greasing bearings, changing transmission oil, checking rotor blades and braking systems, testing the wiring and connections, etc. Maintenance workers may also check the tower for any structural damage that may have been incurred over the year. Annual diagnostics such as these not only keep the system generating its maximum amount of potential power year after year, but they also keep the system from becoming a potential hazard to those working on and around it. By taking care of the equipment and performing these annual inspections, most manufacturers predict a 20-30 year lifetime for their turbines.

#### **5.4.4. Health and Safety Issues**

When it comes to health and safety issues, the cardinal rule of wind power is to keep the area within one hub height plus one rotor distance clear of any critical structures or people. This is primarily due to the fact that if the turbine were ever to collapse, there would be nothing for it to damage.

One of the major safety concerns for wind turbines is the possibility of them throwing a blade that has become damaged and separated from the hub. This was a major concern when wind power was in its infancy, however with today's technology, this is no longer a real worry. Previously, the heavy metallic blades used in wind mills were susceptible to environmental issues and fatigue. Though it was rare for them to actually separate from the hub, they could cause a great deal of damage in the event that they actually did. The long metal blade could travel quite a distance, but more importantly the absence of one of the blades would cause an imbalance on the tower, resulting in tower collapse due to severe vibrations.

The newer blades used today are made of composites and plastics. These do not have nearly the same weight as their metallic predecessors and are also less susceptible to environmental factors. In the extremely unlikely event that the blades would be ejected, they would not travel anywhere near as far as a metal blade.

One of the major causes of blades being thrown is a blade rpm that is too high. With advances in windmill technology, this is much less of a concern. As we saw in our discussion of the cut-out speed for a given turbine, there are a number of safety mechanisms to slow the rotational speed of the rotor in the event that it should get too large.

Another potential problem for consideration is dealing with the New England winter weather. While there might be more wind in the winter, the harsh weather can create layers of

ice on the turbine blades. This ice can be thrown by the turbine as the blade flexes. This is of particular concern if the turbine slows or stops during a storm and then starts later on. The layer of ice that is formed will now be thrown as the blades flex under movement. It is recommended that to insure the safety of the general public, citizens be kept a distance of two to four times the blade-tip height. While the actual distance will depend upon the site, this is a good general rule.

In regards to electrical safety of medium scale wind turbines, technology once again helps prevent disaster. Today's modern turbines incorporate a power controller which monitors the turbine power production, the site's instantaneous electrical needs, and grid power availability. In the situation where grid power might be lost, the power controller will sense the outage and will not try to "force" power into the grid. It does this by directing power solely to the site. If the windmill is producing more power than the site is requiring, the turbines dump load capability will prevent damage to the site. If this is still not enough, the turbine will automatically slow or shut down entirely to prevent damage to electrical circuits.

Wind turbines are quite tall, reaching heights of a couple hundred meters. This proposes an issue with aircraft when the towers are situated in urban areas. While the risk of a collision is quite low as pilots are supposed to stay above one thousand feet in elevation while flying, the FAA imposes restrictions upon towers that are more than two hundred feet tall or are within three and three quarter miles from an airport. This height restriction affects most commercial scale wind turbines. While it is not often that the towers are forbidden unless they are to be situated directly in approach or take off corridors, the FAA requires specific lighting arrangements on the towers. What lighting is needed varies from site to site; in some places the lights need to be red, others white, and some need to run continuously while others need to flash.

Another consideration when installing a wind turbine is possible vandalism. This is more

of a possibility in urban areas with small, guyed pole towers where the rotor is closer to the ground. Adolescents looking to cause trouble can undo the guy wires, causing the tower to come crashing down. Vandalism can occur in more rural areas when firearms are discharged at the blades and generators. This is one of the more common issues, but this vandalism also occurs with regular transmission lines.

#### **5.4.5. Environmental Impacts**

When anything foreign is introduced into the environment, one must consider the effects of such a change or disturbance to the ecosystem. One of the primary concerns is the impact of wind turbines on the local bird populations. It has been theorized that birds will fly into and through the wind turbines unknowingly, resulting in the reduction of local bird populations.[20] This concern arose from a large wind farm at the Altamont Pass in California. The wind farm is constructed of five thousand four hundred turbines closely packed and situated on a major raptor migration corridor, which is also the location of the highest concentration of gold eagles in North America. While there is some evidence to support the bird interaction theory with regards to large wind farms composed of multiple turbines, there is no evidence that a single turbine will have a severe impact. In fact, the impact has been stated to be less than one in thirty thousand (roughly one to two birds per turbine, per year) when compared to other man-made structures such as buildings, traffic, and even house cats [21]. Wind turbine impact on bat populations has not been studied as extensively, but it is theorized that the impact is even lower than that for birds. Conventional fuels used in other forms of electricity-production have a far greater environmental impact due to their pollution of air and water sources.

Wind turbines are tall structures that must rise above all the surrounding buildings and trees. Thus they are quite visible and change the look of the sky line. If situated in a rural area, residents might be unwilling to see the beautiful landscape marred with a turbine. While not everyone will see a turbine as a blemish, it must be considered that some might. In some communities with cell phone towers, the residents have pushed for the cell companies to disguise the tower as a tree, thus lessening the visual effects on the environment. As of now, wind towers do not have the same camouflaging technology.

In addition to impacting the ecological environment, wind turbines also have an impact on the social environment of the human population. One of the first things people are concerned about is the acoustic noise that the windmills generate. Many do not realize that today's turbines are very quiet. When standing a couple hundred feet away, the noise level is comparable to that of a running refrigerator. Bergey Windpower, Co. has performed studies on their 10kw model where at distance of forty two feet from the base of the tower, the sound level was only three to four decibels above the ambient noise of its surroundings. When operated unloaded at high wind speeds, the turbine was actually around fifteen decibels higher than ambient noise, but the advent of dump load circuits allows one to never run the wind mill unloaded [22].

There has also been great concern over the "ghosting" of television screens in homes near the wind mill caused by interference from the rotor blades. While this was a legitimate concern when metal blades were used, today's composite blades do not produce the same electro-magnetic interference. Therefore, ghosting of television screens is no longer a major concern.

## 6. Holy Name Background

Holy Name Central Catholic Junior/Senior High School as part of the Roman Catholic Dioceses of Worcester, Massachusetts is a private school which supports the education of students through grades seven through twelve. The school services nearly 800 students from the central Massachusetts, Worcester Area. The school's main structure, which houses administration and grades nine through twelve, was erected in 1967 at its current location on the school's numerous 43 acre parcel of land on Granite Street [23]. In its construction, the school was designed around electric baseboard heaters that are insulated in asbestos. When the school was designed and built, the hazards of airborne asbestos were not known and the future of electric energy was promising. Unfortunately, incidents around the work in the late seventies and early eighty's, like Three Mile Island and Chernobyl, drastically changed the future of electric power from nuclear sources [24].

As power prices began to rise throughout the last ten years, the school began to assess its power usage and energy problem. The school currently spends nearly \$200,000 a year for electricity, with the electric baseboard heat accounting for 60% - 75% of the bill. An energy assessment was performed to determine possible improvements to the schools infrastructure and heating methods. Minimal improvements were made in terms of insulation and electronic heating controls; however, the underlying problem was determined to be the electric baseboard heat in relation to today's cost of electricity. Due to the health concerns of asbestos and the cost of abatement, it was determined that it was neither financially feasible nor sensible to remove the current heating system while, consequently displacing students to other areas during which a conventional oil or gas system was added to the current building's infrastructure. The asbestos in its current undisturbed state does not pose a health risk [25] and the current heating system is



fully functional despite its need for expensive fuel. Thus, the possibility of a wind turbine to produce the school's own electricity has been considered.

## **7. Feasibility Study**

### **7.1. Site Assessment**

In order to properly assess the feasibility of a wind turbine on Holy Name's property, a wind study that provides real, on site measurements of actual wind speeds was deemed necessary. While area wind maps and local geographic information is available, it was determined in a situation that requires such a large monetary investment, more accurate data must be obtained. Ideally a tower, with a weather station, comparable in height to the proposed wind turbine would be constructed at the prospective wind turbine location to provide an exact measurement of wind speeds to be experienced by the turbine. Many survey companies loan or lease meteorological (MET) towers for this type of site analysis. These towers host an array of anemometers to properly extrapolate wind speeds and should be placed as close to the final turbine location as possible. Due to the variation of wind speeds and temperature ranges, data should be collected for a minimum of one full year. Our design intent was to gather accurate, site specific data that could be used to reinforce the economic feasibility of a wind turbine at Holy Name High School.

### **7.1.1. Meteorological Tower**

After performing a preliminary site analysis we identified several possible turbine locations. The analysis was based on a number of factors which would propose the best possible measurement location. Primarily we surveyed the area for the critical installation constraints. These include elevation, proximity to property lines, proximity to tall obstructing objects, and turbine foundation locations. After weighing the geographic factors and analyzing present and future construction we isolated a turbine location and a meteorological tower location for wind measurement. Unfortunately, in order to construct a weather station for wind measurement in the locations on the property, we were confronted with a number of limiting factors. Primarily, a tower of adequate height to measure wind speed and direction above the tree line was not financially feasible. Renting a MET tower for a year, with installation and monitoring included, would cost close to twenty thousand dollars. Other hindrances included accessibility, permitting, vandalism and proximity to utilities. Therefore, we had to consider alternate locations to place a weather station. We designed a decision matrix to weight the factors that would constrain the construction of the wind tower as shown in Table 2.

Possible Locations	Factors	Existing Elevation	Height Potential	Cost	Fabrication	Power Availability	Vandalism	Time to Completion	Ease of Monitoring	Wind Shear/Data Accuracy	Total	Rank
	Scoreboard at Football Field		8	5	5	8	6	7	7	6	7	59
Roof of School		7	3	9	7	9	10	8	9	4	66	1
Fence at Football Field		10	7	4	5	3	5	6	6	7	53	4
Freestanding in Field		6	8	1	2	2	3	2	5	9	38	5
Roof of Announcers Box		7	5	4	6	5	7	5	6	6	54	3

**Table 2: Decision Matrix for Anemometer Location**

After surveying the property and weighing all options in a decision matrix that weighted time, cost, feasibility, and accuracy of results, it was determined that the most feasible location for a weather station was atop the school’s main building. The deciding parameters included the existing elevation of the school gaining us clearance above the tree line, the close proximity to power, ease of maintenance, and protection from vandalism. To obtain the most accurate wind data, it would be ideal to take measurements from the future turbine height. However, it is also possible to extrapolate data from lower elevations using accepted formulae that account for differences in elevation and obstructions. Although the roof top location solved some of the

more difficult problems, it also created a few of its own. As per Holy Name's insurance policy and city ordinances, structures atop school buildings require special permitting if they rise more than 13ft above the roof. Roof loading also became a concern based on the poor condition of the existing rubber and stone roof. The inability to drill through the roof and minimal mounting points further constrained our design. We also had to be able to raise the tower onto the roof, fit it through the schools doorways, or assemble it in pieces. Despite the challenges the team was faced with, we took measurements and began the design process.

Our final design consisted of a 12 foot tower attached to an existing but no longer functional concrete and brick chimney as shown in Figure 23. Our design intent was to gather accurate site specific data that we could use to reinforce the economic feasibility of a wind turbine at Holy Name High School.



**Figure 23: Existing concrete and brick chimney atop Holy Name (4' x 4' x 5')**

We had to compromise in regard to the height of the tower, but by doing so, we did not have to wait months for timely permitting. The use of the chimney allowed us to fabricate a shortened tower and place the tower close to roof access and power. The chimney also functioned as a strong, rigid base compared to the cinderblocks (as used to moor other objects on the roof like the satellite dish as shown in Figure 24) which could compromise the roof of the building during heavy snow loads.



**Figure 24: Satellite dish mounted on cinder block platform atop Holy Name**

We needed to design a tower to hold our anemometer that would meet all of our design criteria. Our approach was to construct a tower that was relatively small and lightweight so that it could be fabricated at Worcester Polytechnic Institute and hoisted onto the roof of Holy Name using rigging lines. Initially, we assessed the feasibility of a single, non guyed pole with the anemometer on top. Although simple, this design was confronted with a number of challenges. A single pole that is unsupported has a very low natural frequency, which in the presence of wind, has a low alternating forcing frequency that could put the pole into resonance [26]. This

situation could result in inaccurate data and potential damage to the weather station. Wind loading in the ranges of 30 to 40 mph gusts yearly would also cause significant deflections that over time would fatigue the pole and potentially disrupt our data collection. A single non guyed pole would also be difficult to rigidly mount to the roof. Since safety was one of our primary design requirements along with gathering accurate data over a long duration we felt that we would need a more secure guyed tower.

A full, dimensional analysis of the existing concrete chimney was conducted as presented in Appendix A and was used in the design of the tower. With the final design finished as presented in Appendix B, a wooden jig was constructed to mimic the top part of the concrete chimney atop the roof. With the jig constructed, all of the necessary steel parts made out of 1” outer diameter, 0.08” wall thickness AISI 4130 drawn over mandrel tubing that boasts a yield strength of 63100 pounds per square inch [27]. From prints all of the parts were cut to length, holes were drilled, and the tubing was “fish mouthed” for full weld penetration and maximum strength. Once all of the pieces had been fabricated, they were ready to be welded into an assembly as shown in Figure 25, Figure 26 and Figure 27.



**Figure 25: Wooden Jig Constructed, Corner Bracket Being Welded**



**Figure 26: Close Up of Corner Bracket with Supporting Pole Tacked in Place**





**Figure 27: Close Up of Supporting Pole Connection**



**Figure 28: Tower Completed and Ready for Paint**

With the main part of the tower fully welded as shown in Figure 28, the entire structure and its bolt on braces were primed and painted to increase their corrosion resistance and insure a long service life on the rooftop. Black paint was also selected to increase the tower's ability to

melt snowfall that might accumulate on it and keep the electronic systems as warm as possible, since, as preliminary testing shows, we may be reaching the lower limit of the weather stations operating temperature.

At only 9 feet tall, the tower could be constructed of thin walled steel tubing which is not only strong, but lightweight. With safety in mind, we designed the tower to fit over the lip of the chimney and be self supporting. For added safety, the straps were attached to firmly anchor the tower to the chimney. Chisel-point lag bolts were then driven into the concrete to maintain the final position. With triangular gussets and sloped tubing, the tower was rigid and would not deflect significantly under load. However, with an unknown forcing frequency, we guyed the tower's top to the four base corners to reduce, if not eliminate, all bending and increase the natural frequency significantly above the forcing frequency of the wind to ensure the tower would never reach resonance. The guy wires were constructed of stainless steel, 1/8 aircraft cable with a breaking strength of 1780lbs [28]. They were preloaded and safety wired at approximately 100lbs. of tension. We will conduct monthly maintenance to ensure cable tension and check for any corrosion or signs of failure. Over the last nine months, the tower has held up to all environmental elements.

Since the weather station and tower would now be the tallest structure atop Holy Name, we needed to protect the school and weather station from lightning strikes. Fortunately, Holy Name had a current lightning protection system that we would be able to tie into. Atop the peak of the tower, we affixed a 5/8 inch diameter copper electrode as seen in Figure 29, which would carry a lightning current through a 21 strand, 00 gauge, stranded copper wire. The copper wire was laid next to the existing lightning protection system and attached with two split bolt clamps as shown in Figure 30.



**Figure 29: Copper Electrode and Weather Station Affixed**



**Figure 30: Lightning Protection Connection to Existing System**

Now that the tower was fully built, it needed its most integral part; the weather station. There are many weather stations on the market, from the simplest gizmos to the most high-tech devices. While many of the features of the higher end stations were appealing, for the current situation, the station needed simply to record wind speed, direction, and temperature. We decided that the Davis Instrument's Weather Wizard III (see Appendix C) was ideal for our situation. It had all the necessary capabilities that we were looking for, was relatively low cost,

and came with a data logger that could store weeks worth of data, making it available to download to a laptop on a convenient basis. Having set the station to take 10 minute interval data we could now compare the wind information from Holy name to standardized feasibility data.



**Figure 31: Anemometer and Wind Vane**

The addition of the weather station completed the tower. A day was selected with favorable weather conditions for installation. The tower itself was transported in the bed of a pick up truck, and then hoisted to the roof through the use of nylon straps. Once atop the roof, the four corners of the tower were placed over the concrete chimney corners, and the steel straps were bolted on. The guy wires were added last to insure that the tower could withstand any wind that Mother Nature might force it to endure.



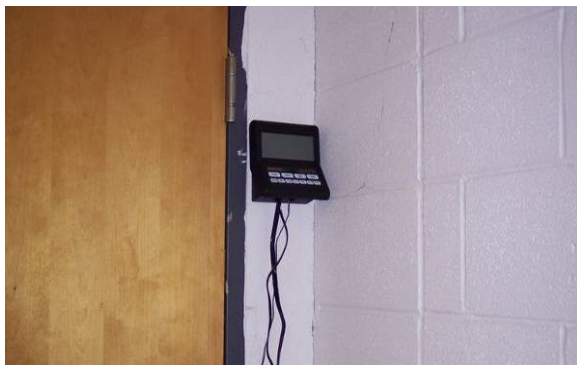

**Figure 32: Corner Bracket and Braces Being Installed**



**Figure 33: Guy Wire Turnbuckle Connection**

Lastly, to prevent lightning damage to the tower and the school, we connected the tower to the existing lightning protection system. With the tower installed, the data logger and display needed to be positioned inside the janitor's closet for ease of information downloading, and the whole assembly was connected to the power as shown in Figure 34. The system was calibrated to due north and appeared to be collecting data without any issues. Throughout the last nine months, the system has functioned nearly flawlessly with no mechanical failures and minimal software glitches. The completed system as shown in Figure 35 has continued to collect important data for the feasibility analysis.



**Figure 34: Weather Station Mounted in Closet**



**Figure 35: Tower Fully Installed**

#### **7.1.1.1. Published Wind Data**

Wind speeds are normally only measured when there is a specific need, such as an airport or a weather collection point for news stations. Some private citizens monitor wind speeds for their own recreation, but it is usually done at a low elevation and is therefore not suitable for use with a wind turbine study. In recent years, there has been a strong push to determine average wind speeds for all areas of the nation. While many measurements are taken to provide data for the wind speed maps, obtaining measurements for every point in the nation is obviously not feasible. Due to the difficulty in getting these accurate measurements, the maps rely heavily on terrain modeling and algorithms to determine the most likely average wind speed, at all different elevations, based off of nearby actual measurements. These wind maps for Massachusetts are available to the general public via True Wind Solutions in collaboration with the Massachusetts Technology Collaborative Renewable Energy Trust (Appendix D).

From analyzing these maps at GPS coordinates (Latitude 42:14:24, Longitude -71:46:48) taken from Holy Name's property, the average wind speed and direction for certain elevations was determined (Table 3 and

Table 4).

**Table 3: Published Average Wind Speeds by Height and Season [29]**

	Avg. Wind Speed (m/s)
30m Annual	5.2
50m Annual	5.7
70m Annual	6.1
100m Annual	6.5
50m Spring	6
50m Summer	4.7
50m Fall	5.5
50m Winter	6.6



**Table 4: Published Average Wind Speeds by Direction [29]**

	Frequency	Avg. Wind
	(Percent)	Speed 50m (m/s)
N	5	5
NNE	5.6	5.2
NE	4.7	4.8
ENE	4.7	4.5
E	3.4	4.1
ESE	2.9	3.5
SE	2.3	3.7
SSE	1.5	4.1
S	3.9	4.8
SSW	7	6.3
SW	11.8	6.3
WSW	12.6	6.8
W	9.9	6.2
WNW	11.7	6.5
NW	7.3	5.9
NNW	5.6	5

A wind rose is also a valuable tool in the analysis of wind potential. A wind rose displays the direction and percentage of the wind on a chart. The published wind rose is shown in Figure 36.

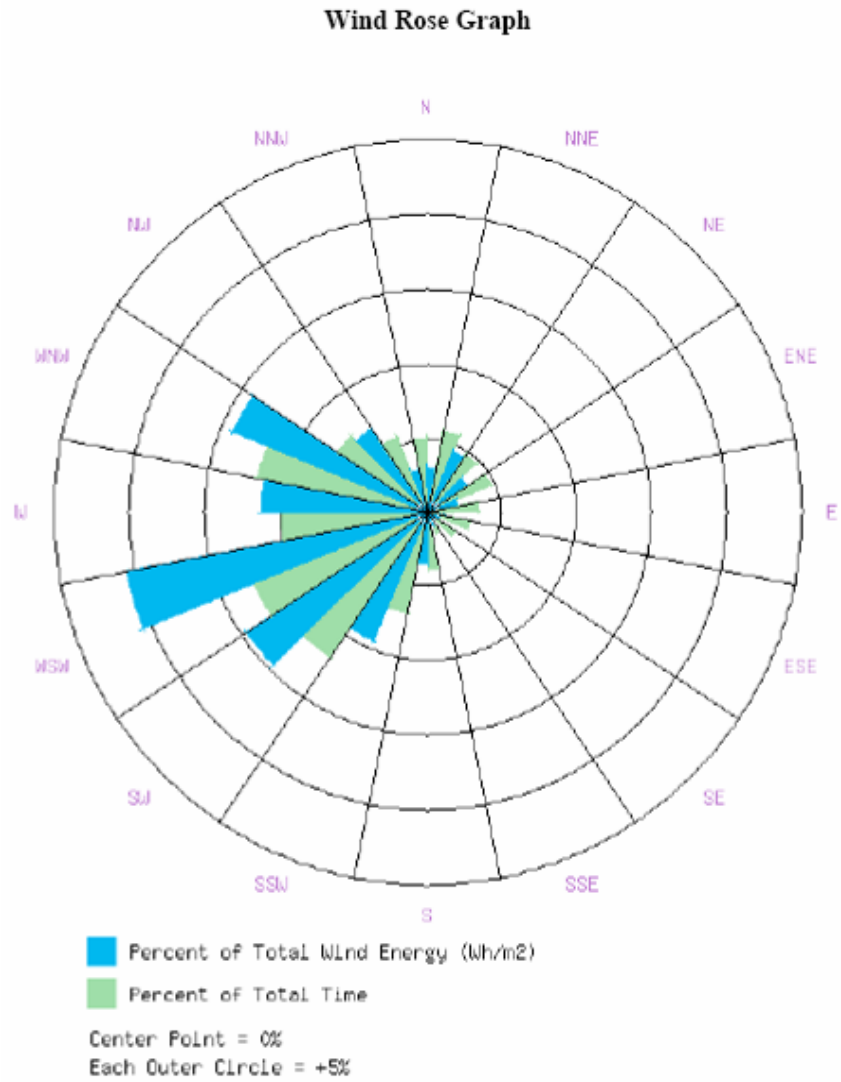

**Figure 36: Published Wind Rose [29]**

Initial observations of the wind maps indicated that a turbine would be feasible at Holy Name. While promising, actual wind speed measurements, at the specific location, are needed before any possible turbine installation commences.

### 7.1.1.2. Collected Wind Data

Throughout the last nine months, the data from the weather station has been recorded and continuously analyzed. Due to the fact that the weather station is not at the same elevation as an actual wind turbine would be situated, a model was needed to extrapolate the collected data to determine the wind speeds at the height of the wind turbine. Wind shear, due to the school building, also needed to be included in this model as it could potentially account for up to an almost fifty percent reduction in wind speed measurements. The anemometer height and the projected turbine height are both known constants. The wind speed at the anemometer is then measured, and the model calculates the theoretical wind speed at turbine height (Figure 37).

Anemometer Height		Wind Speed at Anemometer		Turbine Height		Calculated Turbine Velocity	
(m)	(ft)	(m/s)	(m/h)	(m)	(ft)	(m/s)	(m/h)
20.00	65.62	3.00	6.71	30.00	98.43	4.61	10.30
20.00	65.62	3.00	6.71	35.00	114.83	4.90	10.96
20.00	65.62	3.00	6.71	40.00	131.23	5.17	11.56
20.00	65.62	3.00	6.71	45.00	147.64	5.42	12.12
20.00	65.62	3.00	6.71	50.00	164.04	5.65	12.64
20.00	65.62	3.00	6.71	55.00	180.45	5.87	13.13
20.00	65.62	3.00	6.71	60.00	196.85	6.08	13.59
20.00	65.62	3.00	6.71	65.00	213.25	6.28	14.04
Note: $V_2 = (V_1 / \cos(40)) * (H_2 / H_1)^N$ assuming $N = 0.4$ for wooded areas with tall trees at $H_1$							

**Figure 37: Wind Speed Calculations at Different Height**

The average wind speed at the anemometer height was determined by taking all of the weather data and producing monthly averages (Figure 38). The monthly averages were averaged to get a yearly wind average wind speed at the anemometer height. The average wind speed at Holy Name at the height of the anemometer was 3.0m/s for 6 months, December through May.

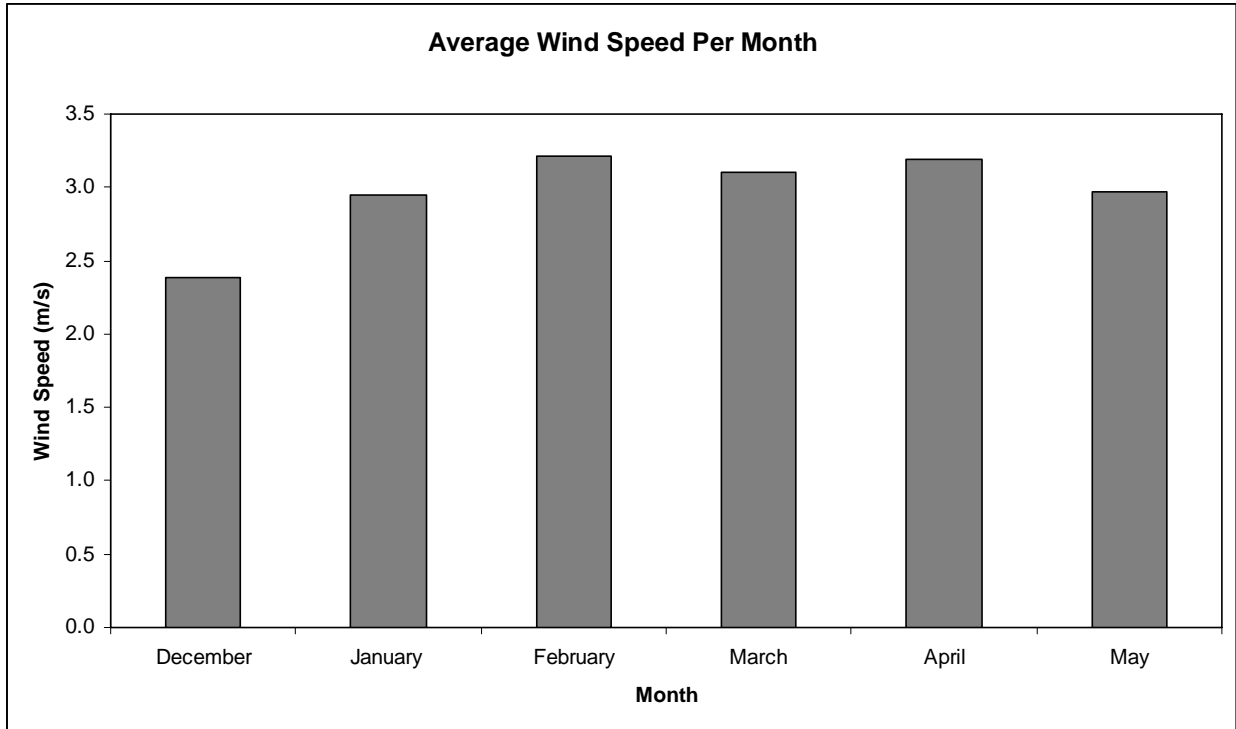

**Figure 38: Average Wind Speed per Month**

By collecting the weather data at Holy Name, the published wind maps could be authenticated and confirmed. The data shows that the published average yearly wind speed is 5.7m/s. The data collected by the anemometer produces a wind speed of 3.0m/s. When the anemometer wind speed is projected up to the appropriate height (50m), the result is a yearly average of 5.65m/s which corresponds directly to the published data.

### **7.1.2. Land Area**

A critical role in the erection of a wind turbine is that of the land area where the turbine will be placed. Without a suitable location to place a turbine, large wind resources and favorable zoning are essentially useless. When searching for a feasible area, many different factors play into the overall equation. One must analyze the surrounding boundaries, utility line locations, elevations, obstacles, easements, ground composition and not only current buildings, but also proposed for the future. When constructing a wind turbine or farm in remote locations, such as a remote ridgeline or open desert in the Western part of the county, many of these factors become less important. When the proposed turbine is to be put in a densely populated area, the issue of surrounding land area is absolutely critical to the success of the project.

Holy Name High School is one such area. Located within the city of Worcester, the layout of the land must be closely scrutinized to not only determine the best location, but if it is even possible to place a wind turbine there. The red in Figure 39 denotes the property that Holy Name does not own.

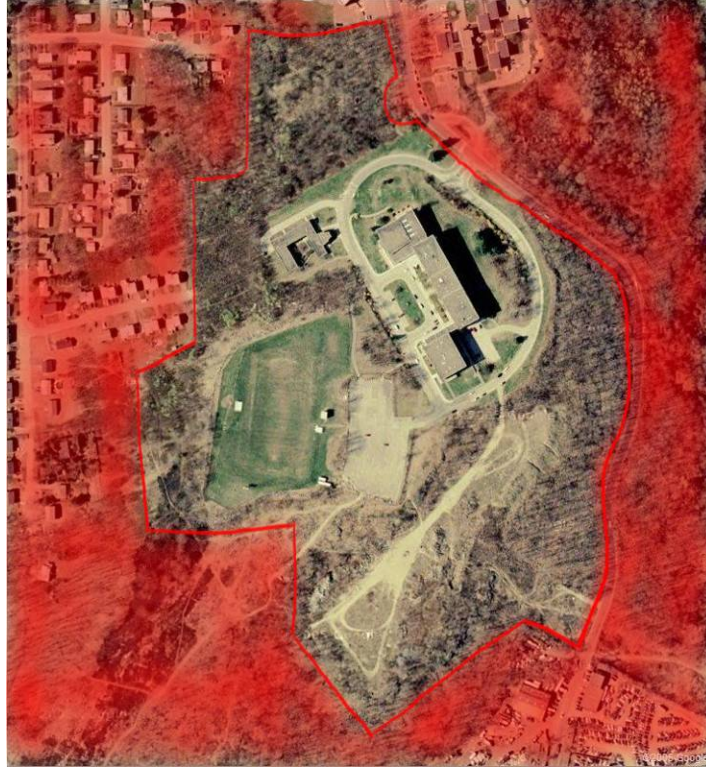

**Figure 39: Property Owned by Holy Name (red area is owned by others)**

### **7.1.2.1. Boundaries**

The first piece of the puzzle to be analyzed is the surrounding property boundaries. The tower must be situated in such a place that in the remote chance that the tower was to fall, it would not fall onto another landowner's property. A proposed turbine for Holy Name would stand at almost 75m from the ground to the tip of a blade, meaning that the tower, at a minimum, should be located 75m from any property line for insurance reasons, as well as zoning ordinances. Figure 40 shows the land available for turbine placement after taking into consideration the property line restrictions. The yellow area is the area in which a turbine cannot be placed due to the proximity to the property boundary.



**Figure 40: Available Land for Turbine with Property Line Restrictions**

### **7.1.2.2. Utility Line Locations**

Next, existing distribution line locations must be analyzed. The turbine must be placed in such a manner that in the remote chance of a fall, it would not land on any existing energized electrical conductors. At the Holy Name location, there is an easement given to National Grid to run distribution lines through Holy Name's property. These lines cut across the property from West to East (Figure 41). The utility line location is outlined in blue.

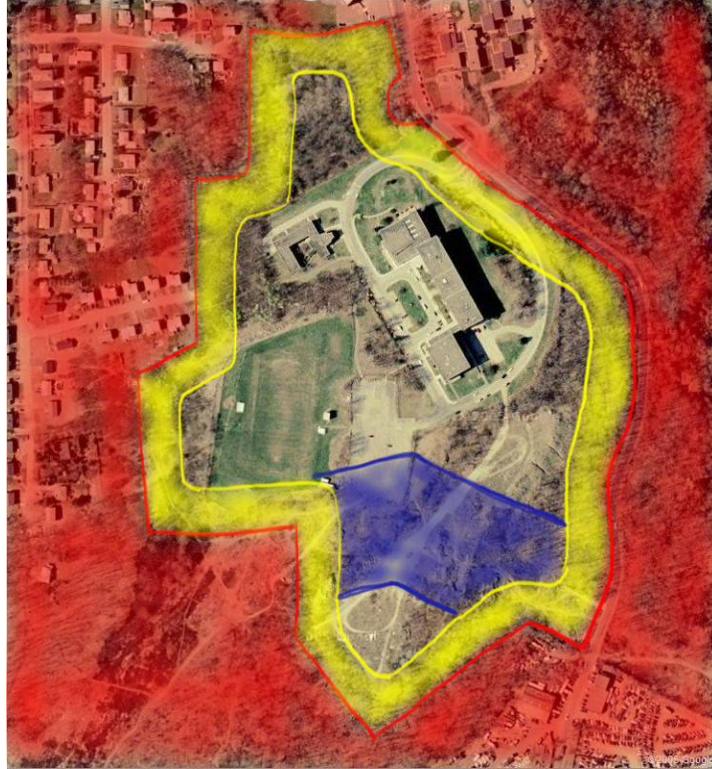



**Figure 41: Existing Utility Lines and Easement**

As before with the property lines, a fall zone must be left between the turbine and the distribution lines. This further reduces the land available to situate the turbine.





**Figure 42: Available Turbine Land with Property Line and Utility Line Restrictions**

### **7.1.2.3. Distance from Neighboring Houses**

Due to the small amount of noise generated by the turbine, it is advisable to situate the turbine roughly 2 times the total height, or roughly 200 meters, from any nearby dwellings as space permits. This should be sufficient since noise studies have concluded that, at a distance of 100 yards, wind turbines are no louder than a regular household refrigerator. Using GPS, it was determined that the closest house to the Holy Name property is approximately 400 ft away, meaning that when the noise restriction distance of 650 ft is taken, it will fall further into the available land than the property line restriction. Thus, in the area by the football field, the limiting factor is the proximity to the neighboring houses.



**Figure 43: Property Line, Utility Line, and Neighboring Dwellings Restrictions**

#### **7.1.2.4. Currently Used Land**

Being in a city, land is at a premium and Holy Name has attempted to utilize their land in the most effective manner. Currently located on the property are the high school and middle school buildings, a football/soccer field, and a practice field. Also located on the property are roadways and a large parking lot, Fig 38.



**Figure 44: Existing Structures and Used Land**

While it might appear from looking at Figure 44 that there is still ample land available, when one takes into consideration all the restrictions, it becomes clear that the amount of available land for the wind turbine installation is very limited.



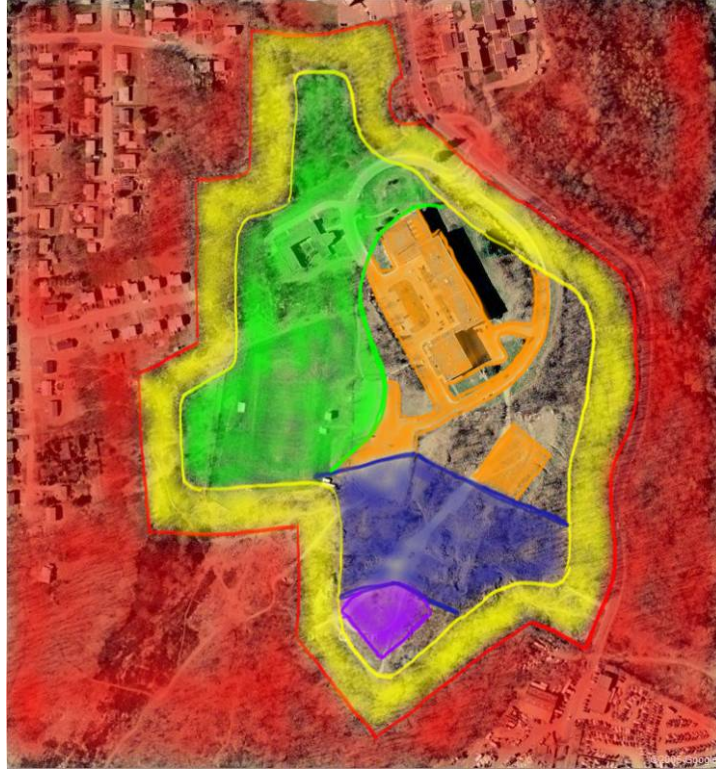

**Figure 45: Available Land with Restrictions**

To further complicate the issue, Holy Name has numerous proposed projects for large parcels of the unused land. On the southern border of their property, a baseball/softball field will be constructed within the next year or two. Located south of the middle school and west of the high school is the proposed location of the new, expanded middle school. On the northern part of their land, Holy Name has already cleared the wooded area to put in a new soccer field. All of these proposed fields and buildings further limit where the turbine could be located.

#### **7.1.2.5. Elevation**

Due to the fact that wind speed increases with elevation, the most favorable site for the turbine is at the spot of highest elevation. Situating the turbine at a higher elevation also decreases the interference that other surrounding structures and vegetation might have on wind speeds. The highest point of elevation, 725 ft, on Holy Name's property is to the extreme west, in a corner just behind the football field. This location is obviously not feasible, because it is

directly next to the property line, close to the neighboring houses, and near the utility lines. The elevation of the property slopes off in all directions, but slopes off gradually in the direction of the high school. Situating a tower up on that area of land would aid in maintaining a high elevation for the turbine base, but it does not fit all the previous mentioned restrictions. A topographical map of the property owned by Holy Name can be found in Appendix E.

#### **7.1.2.6. Grid Interconnection**

Grid interconnection must also be considered when planning where to install the turbine. When choosing between available sites, the site closest to the point of interconnection should be chosen to reduce installation costs associated with running wires from the turbine to the point of interconnection. At Holy Name, the interconnection will need to be in the basement of the school, so placement of the tower closer to the school will aid in reducing installation costs.

#### **7.1.2.7. Environmental Impact**

While no study specifically analyzing the property of Holy Name has been conducted, it is not a known wildlife refuge site. Numerous studies, as stated earlier in Wind Power Technology section, have shown that the addition of one wind tower to a habitat has no significant impact on the bird or bat population. There is no evidence that suggests this would be any different at Holy Name.

#### **7.1.2.8. Conclusions**

Taking all the aforementioned areas into conclusion, there are few locations available for the turbine. One possible location for the tower is on the plot of land between the high school and the large parking lot. This site maintains all the necessary distance restrictions from property lines, utility lines, and neighboring dwellings, as well as a relatively high elevation, 710 ft, and is close to the school where the interconnection will be made. While the ground composition at

this point is not known, it does not differ from any other location on their property. Before construction commences, boring samples of the proposed site should be taken to determine the ground structure and to aid in the design of a sound footing. While this proposed location is within a fall zone of the high school, waivers can be obtained because the school and tower will both be owned by Holy Name. This is an issue that the school must take into consideration since children will often be in the area of the potential fall zone. Also, noise should not be an issue, as the school gymnasium is the closest part of the school to the turbine. Other available land for the turbine is down the hill, behind the driveway and next to the football practice field. A third feasible spot would be directly behind the school in the open grassy area. These alternate locations are slightly less feasible due to lower elevations and further distance from electrical interconnection.



**Figure 46: Proposed Turbine Site**

### **7.1.3. Holy Name Electricity Usage**

Holy Name High School uses, on average, 1.2 million kilo-watt hours (kWh) of electricity a year to heat, light, and power their school. A typical one family home uses about 10-20 kWh a day, or about 4,000 – 7,000 kWh a year. Holy Name uses most of their electricity in the winter due to their electric heat system (see Figure 47).

**Error! Not a valid link.**

**Figure 47: Average Electricity Usage by Month**

About 60% - 75% of the total electricity used by Holy Name is used for the heating in their building. This equates to roughly \$90,000 a year in heating costs. Over the past two years, Holy Name's electricity cost has risen significantly (see Figure 48). This is due to the rising cost of electricity, not to an increase in usage (see Figure 49). Holy Name's electricity usage has decreased slightly in the past years due to moderate winters and due to a computerized control for the heat.

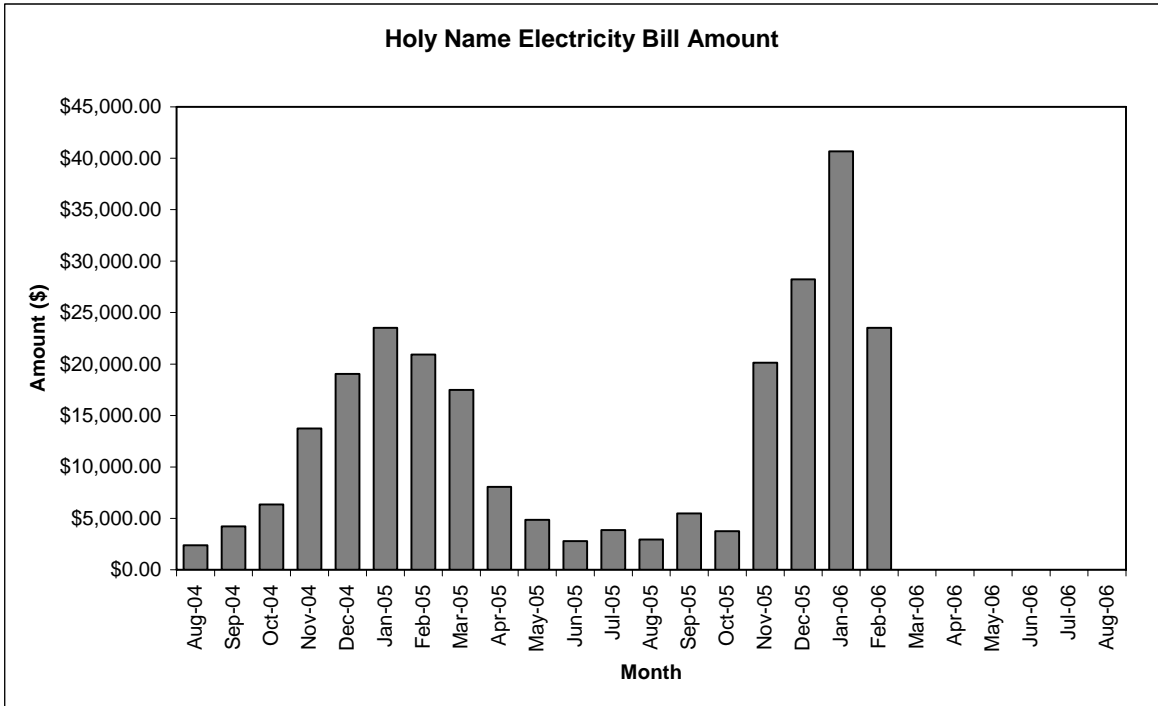

**Figure 48: Holy Name Electricity Bill Amounts**

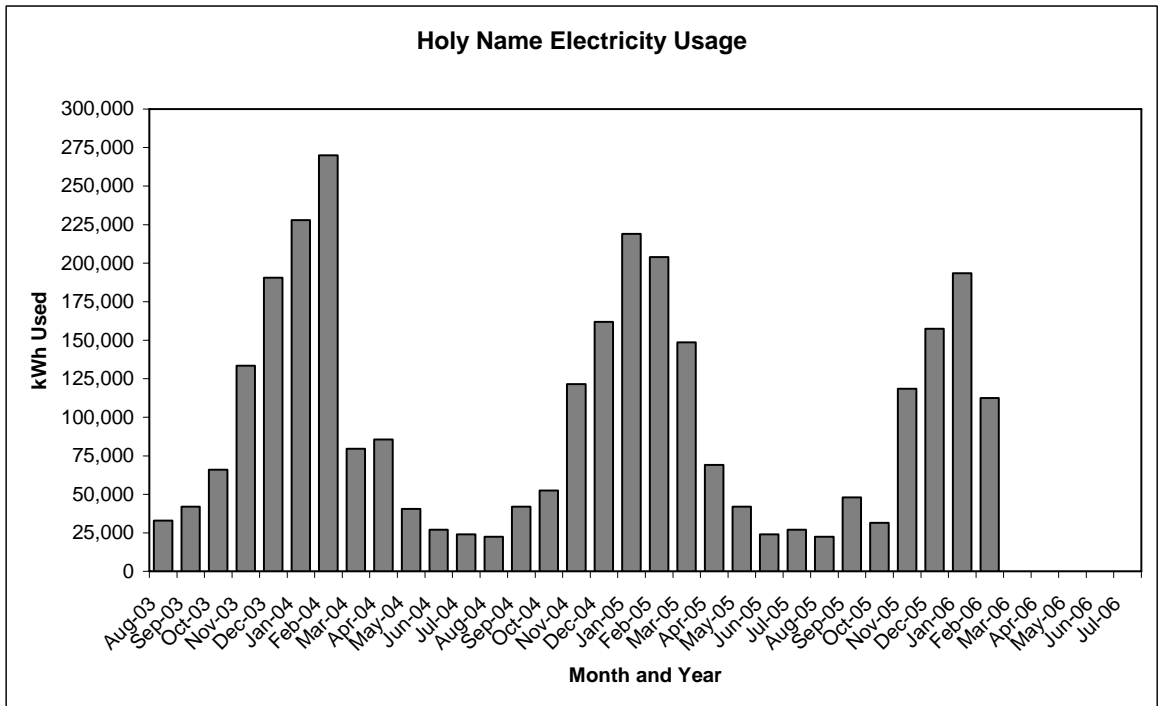

**Figure 49: Holy Name Electricity Usage**



## **7.2. Economics**

### **7.2.1. Turbine Selection**

Turbine selection is one of the most important considerations in a wind turbine project. There are many types and sizes of wind turbines available in the world today. In order to choose a wind turbine to fit a particular situation, information is needed about the site. The most important information needed is the average yearly wind speeds at different heights and the load profile of the building that will be using the generated electricity. The yearly average wind speeds will be used to calculate the expected generation of a wind turbine so that they can be correlated with the load profile. The ideal case would be an expected generation profile that exactly matches the load profile. This would mean that the building would use all the electricity generated by the wind turbine. The closer the load profile gets to the expected generation profile, the better the economics will work out.

The first step in deciding which turbines would work for Holy Name was deciding on the size of the turbine. There are models available from 10kW up to 3MW. This means that at any given time, the maximum output of the wind turbine would not exceed 10kW or 3MW. The 10kW – 50kW models of wind turbines are considered small scale and are intended to be used in single installations where there are small loads. The mid class turbines range from 75kW – 1MW. These turbines are usually used on wind farms and in single installations where there is a moderate load and good wind speeds. The 1MW and up wind turbines are used for large scale installations and offshore installations. The large scale wind turbines are usually used as power plants and not as a means to offset the power consumed at any given location.

Holy Name needed a wind turbine capable of producing roughly 1 million kWh a year with an average wind speed of 5.7m/s. These numbers led to the mid-range wind turbines where many models were investigated. When the companies that made mid-size wind turbines were looked at, three companies had turbines that looked promising; Fuhrlander, Suzlon and Vestas. Specific models of wind turbines from each manufacturer were picked out and pitted against each other.

The models that were looked at from Fuhrlander were the FL250 and the FL600. The Suzlon 950kW model and the Vestas V47-660 and V52-850 were also investigated. Below, Table 5 is shown displaying a comparison between the different models. More information can be found in Appendix F.

**Table 5: Turbine Model Comparisons**

Model	Rotor Diameter (m)	Hub Height (m)	Output (kW)	Cut-In (m/s)	Rated (m/s)
Fuhrlander FL250	29.5	42/50	250	2.5	15
Fuhrlander FL600	43-50	50/75	600	3	10.8
Suzlon 950kW	64	65	950	3	11
Vestas V47-660	47	50	660	4	13
Vestas V52-850	52	40-86	850	4	16

In order to figure out what each turbine would output, an online calculator was used (<http://www.windpower.org/en/tour/wres/pow/index.htm>) where we could put in the average wind speed and other wind distribution data, and the information about each turbine. The calculator would produce a kWh/year measurement which could be compared to the annual Holy Name usage.

Table 6 shows the results from the online calculator.

**Table 6: Turbine Model Output and Capacity Factor**

Model	Annual kWh produced with average wind speed of 5.7m/s	Capacity Factor (%)
Fuhrlander FL250	358,987	16
Fuhrlander FL600	1,349,380	26
Suzlon 950kW	1,359,004	17
Vestas V47-660	1,140,639	20
Vestas V52-850	1,396,237	19

An important consideration is the capacity factor. The capacity factor is basically the used percentage of the wind turbine. If the turbine were to operate at 100% capacity, then the turbine would be outputting its rated output all the time. If the turbine was to operate at 50% capacity, it would be outputting 50% of its rated output all the time, or conversely, it would output its full output 50% of the time. The higher the capacity factor, the more economical the turbine will be.

After analyzing the five different turbines, a conclusion was reached that the two turbines that would best suit the situation would be the Fuhrlander FL600 and the Vestas V47-660. The conclusion was reached based upon the output of each turbine coupled with the capacity factors. Each turbine output close to the 1.2 million kWh that Holy Name uses and both have a decent capacity factor compared to the other models. Another major influence was the cost. The larger the turbine, the greater the price tag. The price for a fully installed FL600 comes close to \$1.4 million US. The price for the V47-660 is around \$1.35 million US. The price for the larger turbines rose up close to \$2 million US. The larger and smallest turbines were not considered economical for Holy Name due to their cost / output. After talking with people in the wind industry, it was discovered that the Vestas V47-660 was no longer being manufactured. Also there were many people that said the Fuhrlander was a better suited machine for places with lower wind speed due to the lower cut-in speed and the power curve.

The power curve of a wind turbine is a plot that shows the output of the turbine for incremental speeds of wind. The power curve for a Fuhrlander is shown in Figure 50.

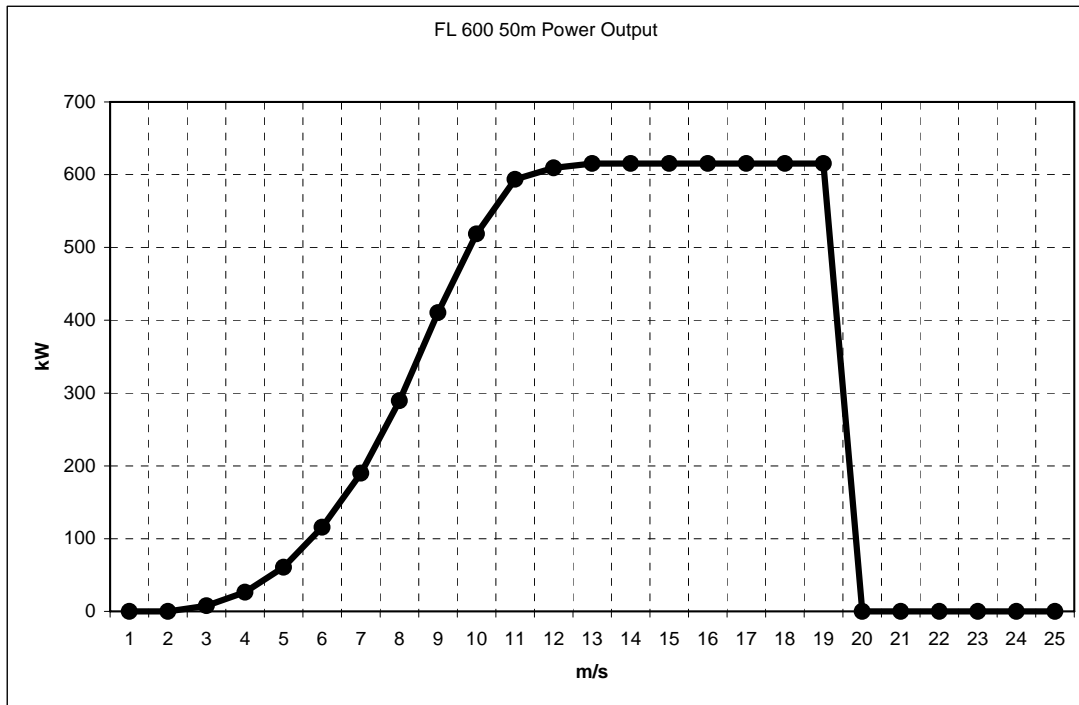

**Figure 50: FL600 50m Power Output Curve**

The power curve of the wind turbine is published by the manufacturer to aid in the analysis of a wind turbine at a specific site. The Fuhrlander is very well suited to the Holy Name site due to the fairly steep slope of the curve. This means that more electricity is produced the faster the wind blows. The steeper the slope of the curve, the “sooner” the turbine produces more electricity per m/s of wind speed increase. Looking at Figure 50 and finding the average speed of the wind at Holy Name (5.7m/s) on the graph and then looking at the corresponding output of the turbine, it looks like the turbine will output approximately 100kW when the wind speed is average. The graph also shows us the cut-out speed of the wind turbine. The wind turbine will automatically stop it’s blade from spinning when the wind exceeds a certain limit. For the

FL600, the cut-out speed is 20m/s. The turbine is designed to stop so that no damage will be done to itself.

### **7.2.2. Expected Generation Profile versus Holy Name Load Profile**

After deciding on a wind turbine model to use, a more in depth analysis needs to be performed to figure out exactly how much electricity the wind turbine will be expected to generate. Other questions to be investigated are how well the generation profile fits with the load profile. In order to figure out how much electricity is expected to be generated, you have to use a statistical model called a Weibull distribution. We used the weibull distribution to figure out how much electricity was expected per month so we could plot it alongside the amount used per month on the electricity bills. Each monthly weibull distribution (See appendix G) takes in the monthly average wind speed, the weibull parameter  $k$  (from published weather data, appendix D), the site altitude, the turbulence factor, and the data from the turbine power curve. The data is utilized and the statistical model outputs a percentage of time that the wind will be blowing at a certain speed. The percentage of time, along with the power output of the turbine at that specific speed, is converted to a kilo-watt-hour measurement. It is then easy to multiply by twenty-four hours in a day and then by the number of days in a month to get the expected monthly output. Figure 51 shows the weibull distributions for each season of the year. Examining the Weibull Distribution, it can be seen that there is a higher percentage of faster wind speeds during the winter months than during any other season. The Weibull distribution is very useful for seeing the percentage of time that a certain wind speed can be expected. Figure 52 shows the expected output of the wind turbine per month.

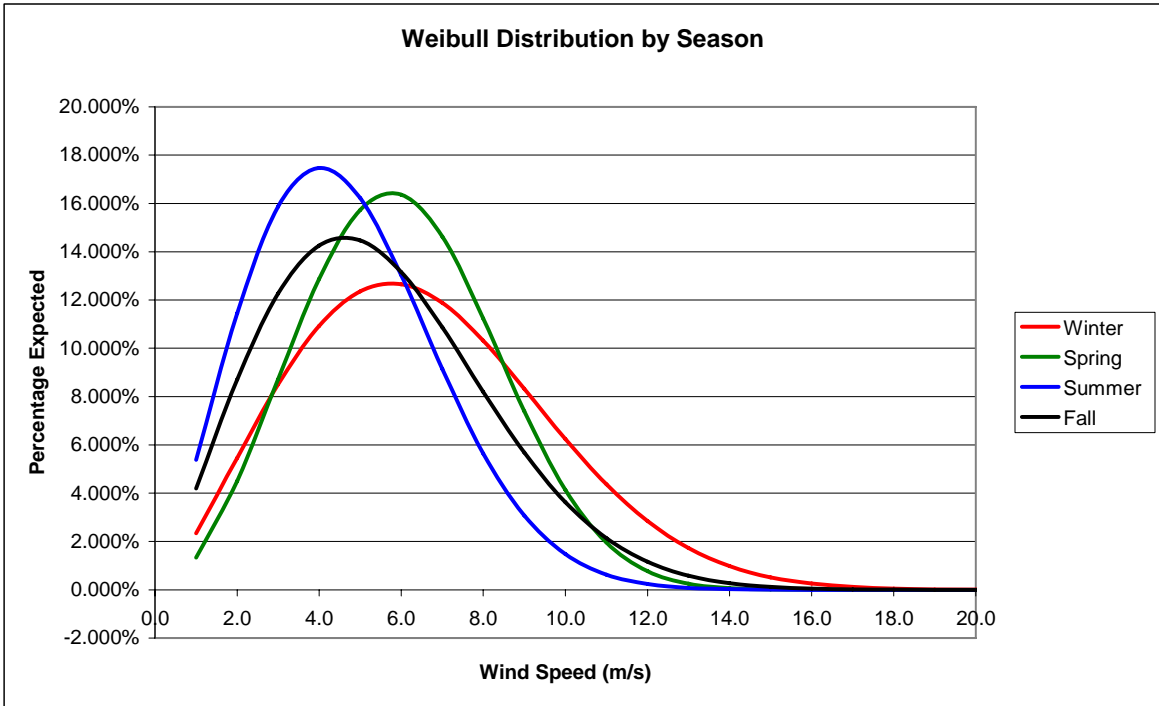

Figure 51: Weibull Distribution by Season

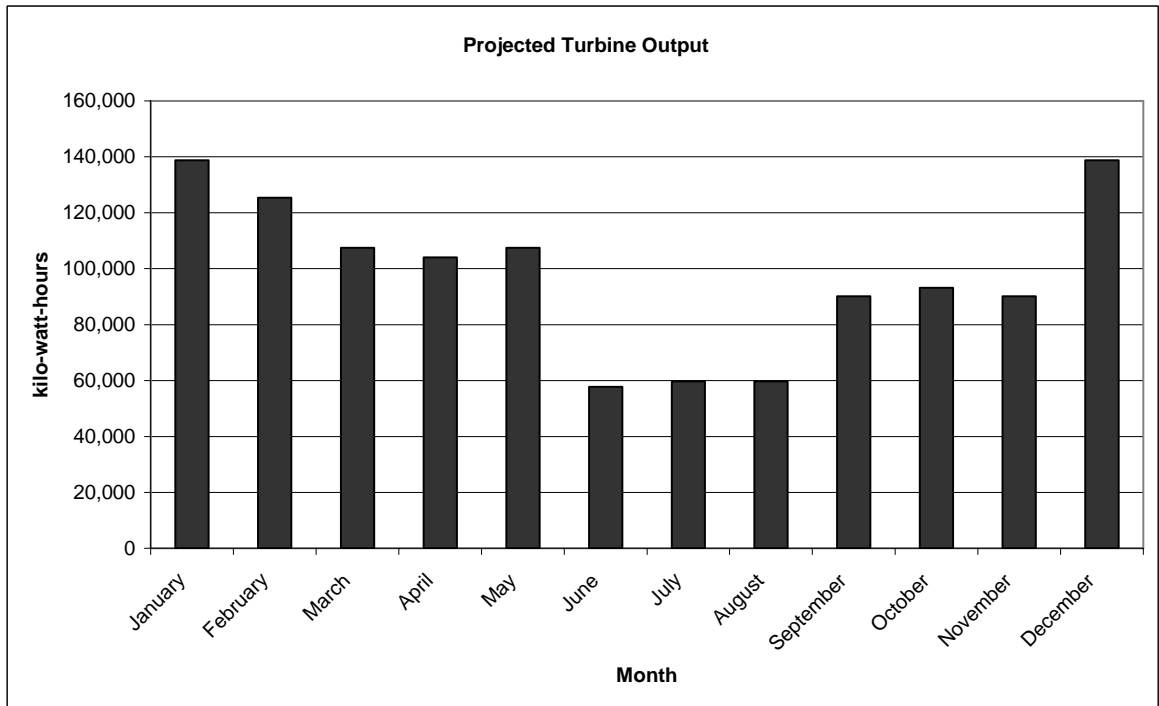
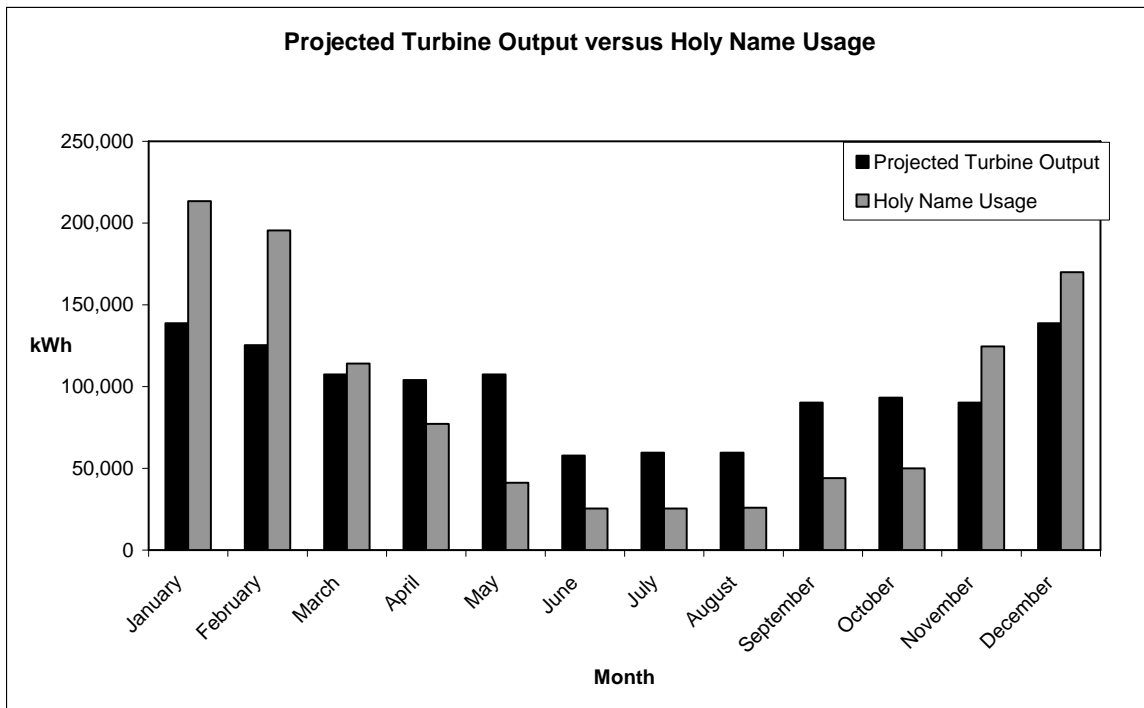

Figure 52: Projected Turbine Output

By taking the projected turbine output and placing it on the same graph as the electricity Holy Name uses on a monthly basis, we come up with a fairly well matched graph. Figure 53 shows the graph of the projected turbine output and the electricity usage together.



**Figure 53: Projected Turbine Output versus Holy Name Usage**

During the winter months, Holy Name uses more electricity than the wind turbine can generate, but during the summer months the wind turbine produces more electricity than the school will use. Overall though, the school uses approximately the same amount as the wind turbine produces in a year or about 1.2 million kWh.



### 7.2.3. Financing

One of the primary detriments to employing wind power is the enormous costs associated with the turbine equipment. With even small-scale turbines of 10 kW or less costing between \$30,000 and \$40,000, the initial expenditures required to purchase the turbine units are much too high to facilitate widespread construction. As energy prices continue to increase, so will the government incentives towards wind power and the high initial costs should begin to come down. Until then however, turbine costs will remain high and construction of new turbines will continue to be a rarity.

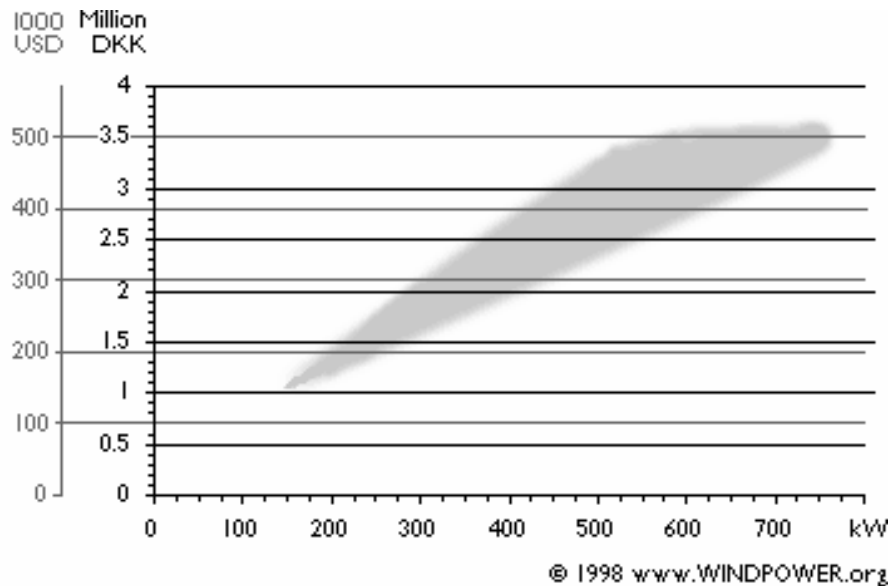

**Figure 54: Average Cost per kW of Rated Output [30]**

The general trend is that as the power output of the turbine increases, the cost per kW of output decreases. We can see this trend in Figure 54, a 200kW turbine will cost around \$200,000, while a 700kW turbine will only cost \$500,000, indicating that larger scale turbines are more cost effective than the smaller scale systems. Typically speaking, small-scale residential systems of 10kW or less cost from \$2400-3000/kW of output, medium scale systems

of 50kW- 1000kW from \$1500-2500/kW and large scale systems of greater than 1000kW from \$1000-2000/kW. The approximate total cost of for the FL600 is \$1.38 million installed.

There are many ways to help offset the initial costs of installing a wind turbine. One way is through grants. There is one major organization in Massachusetts that gives out grants on a bi-yearly basis for the design and construction of wind turbines and other forms of renewable energy. The organization is called the Massachusetts Technology Collaborative or MTC for short. The MTC is located in Westborough, MA. The MTC is in charge of the Large Onsite Renewables Initiative, or LORI grant.

“The Massachusetts Technology Collaborative (MTC), as administrator of the Renewable Energy Trust Fund (the Trust), is seeking applications for the Large Onsite Renewables Initiative to expand the production and use of distributed renewable energy technologies in Massachusetts. MTC seeks to develop a diverse portfolio of renewable energy projects across a variety of locations, technologies, and building types. Round 2 has approximately \$2 million available. Applicants will be subject to a competitive selection process. LORI applicants may request funding in two activity areas: Feasibility Study Grants, and Design & Construction Grants.

- **Design & Construction Grants** are calculated based on an Incentive Matrix. Design grants are capped at the lesser of \$75,000 or 75% of actual cost, and construction grants are capped at the lesser of \$500,000 or 75% of actual costs.
- **Feasibility Grants** are capped at \$40,000 with cost-share of at least 20% or \$5000, whichever is less.

LORI will accept grant applications for development of eligible renewable energy projects(s) with greater than 10 kilowatts of nameplate capacity that are located at commercial, industrial, institutional, and public facilities that will consume more than 50% of the renewable energy generated by the project on-site. The applicant and project site(s) must be a customer of a Massachusetts investor-owned electric distribution utility. The grant awards may be used to facilitate the installation of renewable energy projects on existing buildings (retrofits) or in conjunction with new construction/major renovation projects, including green buildings.” [31]

Holy Name will need to apply for the Design and Construction Grant of \$575,000. The full grant amount would cover about 40% of the total initial cost of the turbine installation. It will be necessary for Holy Name to complete the grant application and file it in time for either the summer or winter submission deadlines.

Another organization that gives out grants is the Sisters of Saint Anne. Ester’s Dream is a grant for up to \$50,000 available through the Sisters of Saint Anne for projects that will benefit society and the environment. This Ester’s Dream grant can be submitted any time and the results are announced within a couple of months of receipt. Holy Name should apply for this grant and use the money to hire a wind consultant.

In addition to grants, Holy Name has the option of taking out a loan from the bank to pay for the whole wind turbine or a partial amount. Ideally, Holy Name would receive a total of \$625,000 from grants. This would dictate a loan for the remainder of the cost. Holy Name has many options when it comes to a loan. There are many banks to choose from and different payback periods. After talking to banks in the area, an interest rate of about 7% was established

as a good interest rate to model with. Considering the scale of the loan amounts, five, seven, ten, and twenty year loan options were examined. Also, to see how much the grant amount would affect the financing, situations where Holy Name received 100%, 90%, 75%, and 50% of the maximum grant amount.

Deciding on which loan to recommend to Holy Name was accomplished by seeing which of the loans met certain criteria. The total yearly payment of the loan had to be comparable to the electricity bills that Holy Name is currently paying. The loan term needed to be minimized to reduce the amount of interest that would be paid on the project, keeping the cost lower.

Table 7 shows the many options that Holy Name has for taking out a loan on the remaining cost of the turbine installation.

Table 7: Loan Options for Holy Name with an FL600

### FL 600 Loan Options

	<b>5 Year Loan</b>			
	100% Grant	90%	75%	50%
Load Amount (\$)	\$755,000	\$817,500	\$911,250	\$1,067,500
Interest Rate (%)	7%	7%	7%	7%
Period (years)	5	5	5	5
Monthly Payment (\$)	\$14,950	\$16,187	\$18,044	\$21,138
Amount Loan Paid Per Year (\$)	\$179,399	\$194,250	\$216,526	\$253,653
Total Amount Paid Over Loan Period (\$)	\$896,994	\$971,249	\$1,082,631	\$1,268,267

	<b>7 Year Loan</b>			
	100% Grant	90% Grant	75%	50%
Load Amount (\$)	\$755,000	\$817,500	\$911,250	\$1,067,500
Interest Rate (%)	7%	7%	7%	7%
Period (years)	7	7	7	7
Monthly Payment (\$)	\$11,395	\$12,338	\$13,753	\$16,111
Amount Loan Paid Per Year (\$)	\$136,740	\$148,059	\$165,038	\$193,337
Total Amount Paid Over Loan Period (\$)	\$957,178	\$1,036,414	\$1,155,269	\$1,353,361

	<b>10 Year Loan</b>			
	100% Grant	90% Grant	75%	50%

Load Amount (\$)	\$755,000	\$817,500	\$911,250	\$1,067,500
Interest Rate (%)	7%	7%	7%	7%
Period (years)	10	10	10	10
Monthly Payment (\$)	\$8,766	\$9,492	\$10,580	\$12,395
Amount Loan Paid Per Year (\$)	\$105,194	\$113,902	\$126,965	\$148,735
Total Amount Paid Over Loan Period (\$)	\$1,051,943	\$1,139,024	\$1,269,646	\$1,487,350

**20 Year Loan**

	100% Grant	90% Grant	75%	50%
Load Amount (\$)	\$755,000	\$817,500	\$911,250	\$1,067,500
Interest Rate (%)	7%	7%	7%	7%
Period (years)	20	20	20	20
Monthly Payment (\$)	\$5,854	\$6,338	\$7,065	\$8,276
Amount Loan Paid Per Year (\$)	\$70,242	\$76,057	\$84,779	\$99,316
Total Amount Paid Over Loan Period (\$)	\$1,404,842	\$1,521,137	\$1,695,579	\$1,986,316

Holy Name currently pays about \$150,000 a year for their electricity. If they were to keep paying approximately the same amount per year and get 100% of the grant money, the ideal loan for them would be a seven year loan. They would be paying about \$200,000 in interest for the loan over the seven year period. If Holy Name only got 50% of the grant money, they would have to take out a ten year loan. The interest on a ten year loan would be around \$400,000. The success of the project will depend a great deal on the dollar amount awarded to Holy Name from these grants.

#### **7.2.4. Net Metering**

Net metering is an extremely important incentive in making wind power and other renewable technologies financially feasible. For any renewable technology that depends on the environment, the power output profiles of these systems are largely unpredictable. For example, the amount of wind present at a particular location for any given instance of time is dependent on a variety of factors, including temperature, barometric pressure, humidity, etc. As a result, there will be days when the wind speed is extremely high, and others when there will be no wind at all. What is most unfortunate is that a generating facility may produce more power than they need on the windy days, while on calm days, they will be forced to buy electricity from the utility. If there were a way for a facility to store the energy generated during windy periods of peak production for use during times of less favorable wind conditions, such an arrangement would enable a facility to maximize the consumption of the energy they produce before needing to rely on a utility.

Net metering is a means of accomplishing this without requiring any physical device for energy storage such as a battery. The conceptual benefit of net metering is the fact that when more energy is being generated than used, the meter that has been tracking the amount of energy that has been consumed from the utility will run backwards, effectively “paying” for the electricity consumed during periods of low production [32].

The most important part of net metering is that the production facility is essentially “selling” their energy at its retail value. In most situations, excess energy is bought by the utility at cost, meaning the price that the utility would pay for electricity before adding their transmission and distribution charges. The difference between the cost and retail values of the electricity can be quite substantial, varying from \$0.05-0.06 /kWh depending on the contract

with the utility. Therefore, by offsetting their energy consumption at the retail price via net metering, a facility will be receiving \$0.05-0.06/kWh more for the energy they produce.

More than 35 states currently employ net metering programs as an incentive for renewable technology, each with a list of conditions and laws specific to their particular agenda regarding energy [33]. Originally conceived by the Department of Public Utilities in 1982 and most recently amended in 1997, the law in Massachusetts stipulates that facilities with a production capacity of 60 kW or less are eligible for net metering with their utility provider. In addition to the daily offset of energy, any net excess generation (NEG) at the end of a month will be credited to the next month's billing period at the average monthly market rate of the energy [34].

As it stands right now, the 60 kW capacity maximum is too low to be applicable to most distributed generation (DG) facilities which look to erect wind turbines ranging from 600 kW – 1.5 MW of production capacity. However, there is work underway as lobbyists push to change the maximum allowable capacity from 60 kW to a much larger value between 1-2 MW. If successful, this change would make net metering a much more viable incentive for those interested in wind power and other forms of renewable technologies.

Unfortunately, due to the size and power production rating of the proposed wind turbine for Holy Name, net metering cannot be currently used. If net metering were to be instituted for capacities below 1MW or 2MW, Holy Name would qualify. Net metering would help immensely with the economics due to the additional \$.05-.06 /kWh essentially “paid” by the utility and the decreased need to purchase electricity from the utility.

### 7.2.5. Energy Certificates

To fully comprehend the incentives associated with Renewable Energy Certificates (RECs), it is important to address a common source of confusion concerning the sometimes ambiguous distinction between the Electricity produced by a renewable source and these RECs. Renewable Energy can be separated into two distinct commodities associated with its production (Figure 55). The elements that comprise renewable energy are the actual kWh of electricity produced, and the “Green” attributes of this electricity since it was produced by a renewable source.

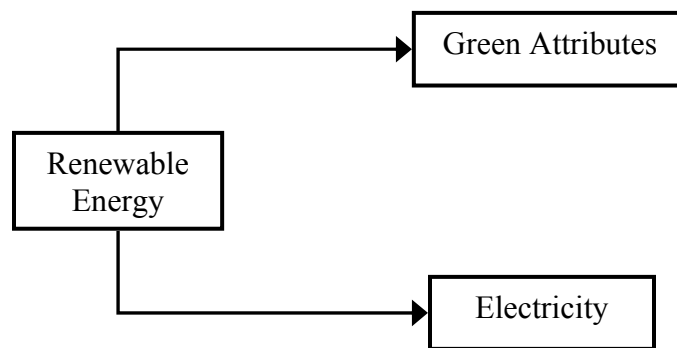

**Figure 55: Breakdown of Renewable Energy Attributes**

Therefore, this additional characteristic of renewable energy has led to the creation of a separate market based exclusively on the green nature of the power being produced. This permits renewable energy sources to capitalize not only on the power they produce, but also on the green nature of their energy supply. The market value of this green power is packaged and traded as these RECs that provided these financial incentives to parties interested in renewable energy.

The trade of Renewable Energy Certificates (RECs) as a financial incentive for constructing renewable sources is a rather new concept that stems from the demand for “green”



energy. Growing concern regarding the global energy situation has resulted in a variety of requirements and agreements concerning the percentage of electricity produced and consumed from renewable sources. Renewable energy “quotas” set by state purchase mandates and environmental disclosure requirements are two examples of such programs that have created a market for green energy [35].

As of 2004, Massachusetts was one of only 15 states across the country to invoke what are called Renewable Portfolio Standards (RPS) for both their Load Serving Entities (LSEs) and retail power suppliers. The RPS requirements are slightly different between the two groups: LSEs must produce a certain percentage of their electricity from renewable sources while retail suppliers are required to obtain and distribute a certain percentage of the electricity they sell from renewables [36]. In 2002, the Massachusetts Division of Energy Resources (DOER) released its regulations for the RPS through the year 2009, dictating the percentage of energy that both LSEs and retail suppliers must annually account for from renewable sources. These percentages can be seen in **Error! Reference source not found.** below.

**Table 8: DOER percentage requirements for renewables [37]**

<b>Year</b>	<b>% of distribution from Renewables</b>
2003	1.0 %
2004	1.5 %
2005	2.0 %
2006	2.5 %
2007	3.0 %
2008	3.5 %
2009	4.0 %
Beyond 2009	Additional 1.0 % annually until DOER terminates requirements

If an LSE or retail supplier does not have a direct affiliation with any renewable sources or cannot meet the percent quota set by the DOER for that year, they may fulfill their renewable

energy requirements through what is called an Alternative Compliance Payment (ACP) to the Massachusetts Technology Park Corporation (MTPC). The ACP covers the RPS percentage that an entity is unable to account for that year. The ACP rate is published on a per megawatt-hour (MWh) basis and fluctuates annually due to inflation. The adjusted rate for the 2006 ACP is \$55.13 per MWh, which is an increase from \$53.19 per MWh in 2005 and \$51.41 per MWh in 2004. Therefore, for every megawatt-hour of production or distribution that an entity is unable to account for as being from a renewable source, that entity must pay \$55.13 to the MTPC as an Alternative Compliance Payment [38].

The RPS green energy requirements are essentially what drive the market for trading RECs. LSEs and retail suppliers seek to form contracts with Renewable Sources to buy the green-nature of their electricity in order to meet their annual RPS requirements. These entities will agree to pay the owner of the renewable source for each REC purchased towards their RPS quota, often on a per megawatt-hour basis at a rate which is close to the ACP value. The production of these certificates by renewable sources is monitored by the New England Power Pool (NEPOOL) and their Generation Information System (GIS). The NEPOOL GIS assesses the power production of a given renewable source and generates the appropriate number of certificates based on their MWh of output for a given month. These monthly amounts of REC production are then made available for trade on a quarterly basis, at which point LSEs and retail suppliers may purchase the RECs for their RPS requirements [39]. By selling these RECs to these entities, the Renewable Source will be considered a 'Brown' facility as opposed to a 'Green' one, since the green-attribute of the power produced has been traded to another party.

The trade of these Renewable Energy Certificates (RECs) provides potential investors in renewable technologies with an added incentive that will procure multiple thousands of dollars

annually in addition to their avoided electricity costs. The additional income from RECs will accelerate the payback period for the technology and also provide an investor with an added sense of security that the return on their investment will be profitable.

### **7.2.6. Tax Incentives**

In addition to the Renewable Energy Certificate programs, there are a variety of tax incentives at both the state and federal level to help promote the creation of renewable energy sources. These incentives include property, income and sales tax exemptions for individuals and organizations across several sectors, including Commercial, Industrial, Municipal and Residential. Given the breadth of this area, we will be focusing on the tax incentives pertinent to Holy Name. A complete list of the State and Federal tax incentives available to the different sectors in Massachusetts can be found at the Database of State Incentives for Renewable Energy (DSIRE) website: <http://www.dsireusa.org/>

As a municipality considering wind power, the lone tax incentive which Holy Name may be able to take advantage of is the state sales tax exemption. Formally referred to as the ‘Renewable Energy Equipment Sales Tax Exemption’, this statute provides an individual or organization with exemption from the Massachusetts state sales tax for the purchase of solar, wind and heat-pump systems and all related equipment [40]. There is no maximum incentive value associated with this statute and it is not available to commercial users. This would provide Holy Name with a savings of thousands of dollars on their initial investment (5% of the cost of the turbine), thereby decreasing their loan requirement and shortening their pay-back period. Other tax incentives, including property and income tax exemption, would be inapplicable to Holy Name’s situation. As a non-profit organization, the school has no taxable income for

which they owe the state a percentage. Additionally, the school is exempt from property taxes due to their affiliation with the Catholic Diocese of Worcester.

### 7.2.7. Economic Model

The economic model was created based upon the information found in each sub-section of the economics portion of the report. First, the electricity bills from the past two years were examined along with the Weibull Distributions. An average for each month of Holy Name’s electrical usage was calculated, and then the twelve months of the year were summed to get a projected average yearly use of 1,107,000 kWh. The monthly projected output from the FL600 is calculated, and then each month is added together to generate a yearly projected output (Table 9). It is known that Holy Name’s demand for electricity will increase over time as more buildings are added to their campus, but for this model, future expansion is not taken into account. Each month of the year is examined and the projected output of the turbine is compared with Holy Name’s usage to generate a monthly difference in electricity produced or purchased. In a year’s time, it is projected that more electricity will be sold back to the utility than purchased (Table 9).

**Table 9: Electricity Bill Analysis and Average Usage and Production Numbers**

Month	Turbine Output (kWh)	Average Electricity Use (kWh)	Net Purchased (kWh)	Net Sold (kWh)
January	138,755	213,500	74,745	0
February	125,327	195,500	70,173	0
March	107,503	114,000	6,497	0
April	104,035	77,250	0	26,785
May	107,503	41,250	0	66,253
June	57,798	25,500	0	32,298
July	59,725	25,500	0	34,225
August	59,725	26,000	0	33,725
September	90,165	44,000	0	46,165
October	93,171	50,000	0	43,171
November	90,165	124,500	34,335	0
December	138,755	170,000	31,245	0
<b>Totals:</b>	<b>1,172,628</b>	<b>1,107,000</b>	<b>216,995</b>	<b>282,622</b>

Next, costs associated with electricity were considered. It is projected that the cost of electricity to consumers will rise 3% every year [41], starting from the 2006 average cost of delivered electricity, \$0.15 / kWh. The cost of electricity to the electric companies will also grow and remain at \$.06 below the cost of delivered electricity (Figure 56).

**Error! Not a valid link.**

Figure 56: Projected Electricity Cost

The projected cost of electricity is important so that an accurate picture can be painted of the future. The delivered cost of electricity is important because it will show how much cost Holy Name is offsetting by having a wind turbine. The cost of electricity to utilities is important because it is the amount that a utility will pay Holy Name for any excess electricity they produce and don't use (Figure 57). Over a 20 year period, Holy Name is expected to offset close to \$4.6 million in electricity costs.

**Error! Not a valid link.**

Figure 57: Electricity Purchased and Sold

Another big contributor to the economics of a wind turbine installation are the Renewable Energy Certificates or RECs. The owner of a wind turbine may sell their REC's to generate additional income. The contract length for the RECs is usually 10 years. The current rate for RECs is \$0.04 / kWh produced by the wind turbine. If Holy Name were to enter into a contract to sell RECs at \$0.04 / kWh for the next 20 years, they will have earned more than \$900,000 or about 70% of the initial cost of the wind turbine.

The 20 year outlook for Holy Name with a turbine is very good. If they receive at least 75% of the grant money and finance the rest, over the next 20 years, they will be paying \$0.011 to \$0.047 \$/kWh for their electricity, which is very good compared to the projected cost of \$0.30 / kWh in 20 years (Table 10).



**Table 10: 20 Year Cost Analysis**

<b>Electricity Consumption (kWh)</b>	22,140,000	
<b>Net Turbine Production (kWh)</b>	23,452,552	
<b>Sell-Back Energy (kWh)</b>	5,652,446	
<b>Purchased Energy (kWh)</b>	4,339,894	
<b>Purchased Electricity Expense</b>	\$927,873	
<b>Operating and Maintenance Expense</b>	\$228,000	
<b>Total Expense</b>	\$1,155,873	
<b>Sell-Back Energy Income</b>	\$869,351	
<b>REC Income</b>	\$938,102	
<b>Total Income</b>	\$1,807,453	
<b>Loan Payment: 5 Year Loan With 100% Grant Money</b>	\$896,994	
<b>Loan Payment: 7 Year Loan With 100% Grant Money</b>	\$957,178	
<b>Loan Payment: 10 Year Loan With 100% Grant Money</b>	\$1,051,943	
<b>Loan Payment: 20 Year Loan With 100% Grant Money</b>	\$1,404,842	
<b>Loan Payment: 5 Year Loan With 75% Grant Money</b>	\$1,082,631	
<b>Loan Payment: 7 Year Loan With 75% Grant Money</b>	\$1,155,269	
<b>Loan Payment: 10 Year Loan With 75% Grant Money</b>	\$1,269,646	
<b>Loan Payment: 20 Year Loan With 75% Grant Money</b>	\$1,695,579	
		\$/kWh
<b>Total Costs: 5 Year Loan With 100% Grant Money</b>	\$245,414	\$0.0111
<b>Total Costs: 7 Year Loan With 100% Grant Money</b>	\$305,598	\$0.0138
<b>Total Costs: 10 Year Loan With 100% Grant Money</b>	\$400,363	\$0.0181
<b>Total Costs: 20 Year Loan With 100% Grant Money</b>	\$753,262	\$0.0340
<b>Total Costs: 5 Year Loan With 75% Grant Money</b>	\$431,050	\$0.0195
<b>Total Costs: 7 Year Loan With 75% Grant Money</b>	\$503,689	\$0.0228
<b>Total Costs: 10 Year Loan With 75% Grant Money</b>	\$618,066	\$0.0279
<b>Total Costs: 20 Year Loan With 75% Grant Money</b>	\$1,043,999	\$0.0472

Table 10 is the twenty year cost analysis for the project. To calculate the total costs with each type and loan case, the profits and expenses are added up (expenses are negative). The expenses consist of the Total Expense and the Finance Expense (Loan payments). The profits come from the sale of RECs and the electricity that Holy Name sells back to the utility company. Once the total cost has been determined, the price per kilo-watt-hour can be calculated. The price per kilo-watt-hour is simply the total costs over a time period divided by the total number of kilo-watt-hours used by the school in that time period. The ideal case for Holy Name would be to pay more in the beginning by taking out a loan for only 5 years. This will mean that over the next 20 years,

Holy Name would be paying \$0.011 / kWh, which is extremely attractive. It is shown by Table 10 that with all of the financial factors accounted for, it is definitely economically feasible for a wind turbine installation at Holy Name



## 8. Project Achievements

As of May 1<sup>st</sup>, 2006, our team had determined it economically feasible for Holy Name to install a wind turbine. This decision was based on the following information:

1. The school's demand for electricity
2. Experimental verification for the availability of sufficient wind speeds on site
3. The duration of the payback period dependent upon a variety of financial factors such as incentives and interest rates.

Our recommendation is for the school to install a 600 kW turbine atop a 50 meter (approx. 164 ft) tower. Such a turbine would produce 60-70% of the school's electricity during the peak demand periods in the winter months. Depending upon the proportion of the installation costs covered by a loan taken out by Holy Name, the payback period for this turbine is 5 to 8 years. Therefore, if school's annual electricity costs remain close to the \$200,000 predicted for this fiscal year, they will begin saving somewhere between \$120,000-140,000 per year at the conclusion of the payback period.

Furthermore, we have compiled a list of suggested installation sites on Holy Name's property where the wind turbine could be erected. These sites were determined based on a thorough assessment of the terrain and property. Using topographical maps, site survey information and aerial photographs, our team studied the zoning regulations, line-of-sight considerations with adjacent property, noise pollution, and site access for construction vehicles.

In addition to determining the feasibility of the project, our team assisted Holy Name in acquiring \$50,000 from the Esther's Dream Fund, distributed by the Sisters of St. Anne in Lachine, Quebec. Our contribution to the school's grant application included a description of the project goals, the timeline for completion, and its overall benefit to the school, society and

environment. Upon review, Esther's Dream agreed to fund our project in the amount of \$50,000 for initial expenses such as consulting, legal fees, etc.

On May 5<sup>th</sup>, 2006, our team organized a trip to see the Vestas V47-660 wind turbine at the Portsmouth Abbey School in Portsmouth, RI. Our intent was to show our project sponsor, Headmaster Mary Riordan, an actual unit, similar to what we were recommending for Holy Name and provide a first-hand experience of what we have been striving for.

At the request of Headmaster Riordan, we were invited to a meeting at the Massachusetts Technology Collaborative (MTC) in Westborough, MA on May 16<sup>th</sup>, 2006. In attendance were Congressman James P. McGovern and his Chief of Staff, Chris Philbin, who were present at the request of Mrs. Riordan to help facilitate the construction of a wind turbine in Worcester, MA. Our team presented our results to the Congressman, after which the group then engaged in a discussion concerning the next steps to get a turbine on Holy Name's property. Congressman McGovern was extremely pleased with our work and offered any assistance that he could provide at the federal level.

Following the meeting with Congressman McGovern, our team filed obstruction evaluation forms with the Federal Aviation Administration (FAA) for three possible turbine locations on Holy Name's property. These forms required specific coordinates and elevations for each of our three locations, as well as any details regarding the turbine we planned on erecting. At the time of project submission, the FAA was processing our requests.

On July 11<sup>th</sup>, 2006, our team passed the project to wind power consultant hired by Headmaster Riordan. Kevin Schulte of Sustainable Energy Developments, Inc. was recommended to the Headmaster by our team after meeting him at the Building Energy '06 conference in Boston, MA, and his hiring was made possible by the money received from the

Esther's Dream grant. Our team sent Kevin all of our files pertaining to our economic model and gathered wind data from our weather station atop the main building at Holy Name. On August 17<sup>th</sup>, 2006, Kevin submitted a grant application for design and construction to the Large Onsite Renewables Initiative (LORI) fund distributed by MTC for \$575,000 dollars. The results of this submission will be available in early November, 2006.

## 9. Project Conclusions

As energy prices continue to increase in the coming year, Holy Name is in desperate need of a viable solution to the problem that they are faced with. The installation of a wind turbine on their property would dramatically reduce the annual cost of heating their buildings with electricity. Our team predicts that if the school were to install a 600 kW wind turbine, they would save between 60-70% of the total cost they would be charged by the electric utility for the number of kilo watt hours (kWh) that they consume annually.

If we take the school's projected heating costs for the upcoming fiscal year as an example, a 600 kW wind turbine would have saved the school between \$120,000-140,000 of the approximately \$200,000 that they will pay for electricity this year. An annual savings of this magnitude would enable the school to pursue several initiatives in improving the quality of the education offered to the students. These improvements would include an expedited implementation of the school's technology plan, an increase in the amount of financial aid offered to the students, and the various repairs and improvements required by a 40 year old school building [42].

In addition, a wind turbine would be an incredible educational opportunity for the students at Holy Name. The school strives to teach its students to be good stewards of the environmental resources available to them and a wind turbine on campus would exemplify this important life lesson. Academically, the science classes will be able to take full advantage of the data concerning wind speed and direction as they integrate this information into their curriculum regarding the societal benefits of utilizing renewable energy sources [42].

If the school is unable to secure the installation a wind turbine, the annual cost of heating the building is sure to grow as the price of electricity continues to increase. This will force Holy

Name to make some very difficult financial decisions that will affect the school in many ways. Academic programs, Men's and Women's athletics, and other extracurricular activities will be cut from the budget if the school is forced to put more money towards heating their facilities [42].

It is absolutely essential that Holy Name succeed in erecting a wind turbine. Beyond the benefits to the school, a wind turbine in Worcester, MA would serve as a landmark of change. As we march onward into the next century, we are already faced with an impending energy crisis. The implementation of wind power and other renewable sources of energy are extremely important if we as a society are intent upon maintaining our everyday lives as we know them.

## 10. References

- [1] Short Term Energy Outlook. EIA: Energy Information Administration. 1/10/2006.  
<http://www.eia.doe.gov/emeu/steo/pub/contents.html>
- [2] North America: The Energy Picture. North American Energy Working Group. June, 2002. <http://www.eia.doe.gov/emeu/northamerica/engsupp.htm>
- [3] Coal Energy. EIA: Energy Kid's Page.  
<http://www.eia.doe.gov/kids/energyfacts/sources/non-renewable/coal.html#uses>
- [4] Coal. University of Colorado.  
<http://lsa.colorado.edu/summarystreet/texts/coal.htm>
- [5] Table 10c: U.S. Regional Electricity Prices. EIA: Energy Information Administration.  
<http://www.eia.doe.gov/emeu/steo/pub/contents.html>
- [6] History of Wind Energy: Charles F. Brush. Danish Wind Industry Association. July 23, 2003. <http://www.windpower.org/en/pictures/brush.htm>
- [7] History of Wind Energy: Poul la Cour. Danish Wind Industry Association. May 12, 2003  
<http://www.windpower.org/en/pictures/lacour.htm>
- [8] History of Wind Energy: 1940-1950. Danish Wind Industry Association. July 23, 2003  
<http://www.windpower.org/en/pictures/fifties.htm>
- [9] History of Wind Energy: Johannes Juul. Danish Wind Industry Association. July 23, 2003  
<http://www.windpower.org/en/pictures/juul.htm>
- [10] Wind Indicators. The Weather Shop.  
[http://www.weathershop.com/wind\\_.htm](http://www.weathershop.com/wind_.htm)
- [11] Distribution of Energy by Direction. Our Wind.  
[http://www.ourwind.org/windcoop/graphics/TurbineGraphs/Liberty%20County/Marble%20Wind%20Rose%2010\\_28\\_04.jpg](http://www.ourwind.org/windcoop/graphics/TurbineGraphs/Liberty%20County/Marble%20Wind%20Rose%2010_28_04.jpg)
- [12] Darrieus Turbine. The Encyclopedia of Alternative Energy and Sustainable Living.  
[http://www.daviddarling.info/images/vertical-axis\\_wind\\_turbine.jpg](http://www.daviddarling.info/images/vertical-axis_wind_turbine.jpg)
- [13] Vestas Wind Turbine. Global Energy Equipment.  
[http://www.globalenergyequipment.com/global2.nsf/c99a3390594d71b385256d850051a821/852570890042338c85256e6300555d38/\\$FILE/AB-M750.jpg](http://www.globalenergyequipment.com/global2.nsf/c99a3390594d71b385256d850051a821/852570890042338c85256e6300555d38/$FILE/AB-M750.jpg)
- [14] Major Components of a Wind Turbine. The Energy Manual.  
[http://www.energy.iastate.edu/renewable/wind/wem/images/wem-07\\_fig01.gif](http://www.energy.iastate.edu/renewable/wind/wem/images/wem-07_fig01.gif)

- [15] A Strategic Location for Wind Turbines. Invest in Denmark.  
[http://www.investindk.com/db/pub/Wind\\_energy/images/WindEnergy\\_Aug04x2x1.jpg](http://www.investindk.com/db/pub/Wind_energy/images/WindEnergy_Aug04x2x1.jpg)
- [16] Thumbnails of Nordex Pictures. Nordex.  
<http://sales.nordex-online.com/Fotos/N52-lattice-tower.jpg>
- [17] Wind Generator Towers. Wholesale Solar.  
[http://www.wholesalesolar.com/images/wind\\_folder/airx\\_47\\_tower.gif](http://www.wholesalesolar.com/images/wind_folder/airx_47_tower.gif)
- [18] Tri-State Renewable Resources.  
<http://www.tristategt.org/greenpower/images/wind-turbine.jpg>
- [19] Wind Turbine Construction. Pincher Creek. [http://www.pincher-creek.com/windenergy/construction\\_pictorial.htm](http://www.pincher-creek.com/windenergy/construction_pictorial.htm)
- [20] Audubon Society of California Letter in Support of Wind Turbines. July 17, 2001.
- [21] Letter to Mr. Bergey, CEO of Bergey Windpower . Department of Zoology, University of Oklahoma. June 22, 2001
- [22] Migliore, P. “Acoustic Tests of Small Wind Turbines” National Renewable Energy Laboratory.
- [23] Holy Name Handbook. Holy Name Central Catholic Junior/Senior High School. 2006.  
<http://www.holyname.net/handbook/hdbk2006.pdf>
- [24] Three Mile Island. Wikipedia. 2006.  
[http://en.wikipedia.org/wiki/Three\\_Mile\\_Island](http://en.wikipedia.org/wiki/Three_Mile_Island)
- [25] Asbestos. Wikipedia. 2006.  
<http://en.wikipedia.org/wiki/Asbestos>
- [26] Norton, Robert. Machine Design An Integrated Approach. p. 548. Prentice Hall. 2006.
- [27] AISI 4130 Steel. MatWeb. 2006.  
<http://www.matweb.com/search/SpecificMaterial.asp?bassnum=M4130C>
- [28] Stainless Steel Wire Rope. McMaster-Carr. 2006.  
[www.mcmaster.com/8908T12](http://www.mcmaster.com/8908T12)
- [29] New England Wind Maps. AWS TrueWind. <http://truewind.teamcamelot.com/ne/>
- [30] Economics: Turbine Costs. Danish Wind Industry Association. May 12, 2003.  
<http://www.windpower.org/en/tour/econ/index.htm>

- [31] Large Onsite Renewables Initiative. Massachusetts Technology Collaboration.  
[http://www.masstech.org/RenewableEnergy/large\\_renewables.htm](http://www.masstech.org/RenewableEnergy/large_renewables.htm))
- [32] Net Metering. Odysen: Renewable Energy Portal.  
<http://www.odysen.com/netMetering/main.php>
- [33] Net Metering Policies. U.S. Department of Energy – Energy Efficiency and Renewable Energy: Green Power Network  
<http://www.eere.energy.gov/greenpower/markets/netmetering.shtml#ma>
- [34] Issue: Net Metering. State Environmental Resource Center: Innovative State Legislation.  
<http://www.serconline.org/netmetering/stateactivity.html>
- [35] Introduction to Renewable Energy. Evolution Markets LLC.  
[www.evomarkets.com/rec](http://www.evomarkets.com/rec)
- [36] Renewable Energy – Market Background. Evolution Markets LLC.  
[www.evomarkets.com/rec/index.php?xpl=1](http://www.evomarkets.com/rec/index.php?xpl=1)
- [37] Renewable Energy Certificates. Evolution Markets LLC.  
[www.evomarkets.com/rec/index.php?xpl=2](http://www.evomarkets.com/rec/index.php?xpl=2)
- [38] State and Regional Compliance Markets: Intro. Evolution Markets LLC.  
[www.evomarkets.com/rec/index.php?xpl=3](http://www.evomarkets.com/rec/index.php?xpl=3)
- [39] State and Regional Compliance Markets: NEPOOL. Evolution Markets LLC.  
[www.evomarkets.com/rec/index.php?xpl=3&mk=2](http://www.evomarkets.com/rec/index.php?xpl=3&mk=2)
- [40] Massachusetts Incentives for Renewable Energy. DSIRE.  
[www.dsireusa.org/library/includes/incentive2.cfm?Incentive\\_Code=MA05R&state=MA&CurrentPageID=1](http://www.dsireusa.org/library/includes/incentive2.cfm?Incentive_Code=MA05R&state=MA&CurrentPageID=1)
- [41] National Grid. <http://www.nationalgridus.com/masselectric/>
- [42] FW: Wind Project Info From WPI. (email). Headmaster Mary Riordan.  
[mrriordan@holyname.net](mailto:mrriordan@holyname.net). Sept. 19<sup>th</sup>, 2006



## 11. Resources

Renewable Energy Research Laboratory (RERL). Sally D. Wright  
<http://www.ceere.org/rerl/index.html>

Pincher Creek & Area Wind Power Capital of Canada. Rainy Day Digital  
[http://www.pincher-creek.com/windenergy/construction\\_pictorial.htm](http://www.pincher-creek.com/windenergy/construction_pictorial.htm)

Massachusetts Technology Collaborative (MTC). Tyler Leeds and Kristin Burke  
<http://www.mtpc.org/>

Massachusetts Division of Energy Resources (DOER)  
<http://www.mass.gov/doer/>

Lorax Energy Systems, LLC. Henry DuPont  
<http://www.lorax-energy.com/>

Northeast Sustainable Energy Association  
<http://www.nesea.org/>

Holy Name Jr. / Sr. High School. Ms. Mary Riordan.  
<http://www.holyname.net/>

Sustainable Energy Development, Inc. Kevin Schulte  
[www.sed-net.com](http://www.sed-net.com)

Sustainable Energy Solutions, Inc. Louis J. Casey  
[www.sustainable-energy.us](http://www.sustainable-energy.us)

12. Appendices

12.1. Appendix A: Dimensional Analysis of Chimney

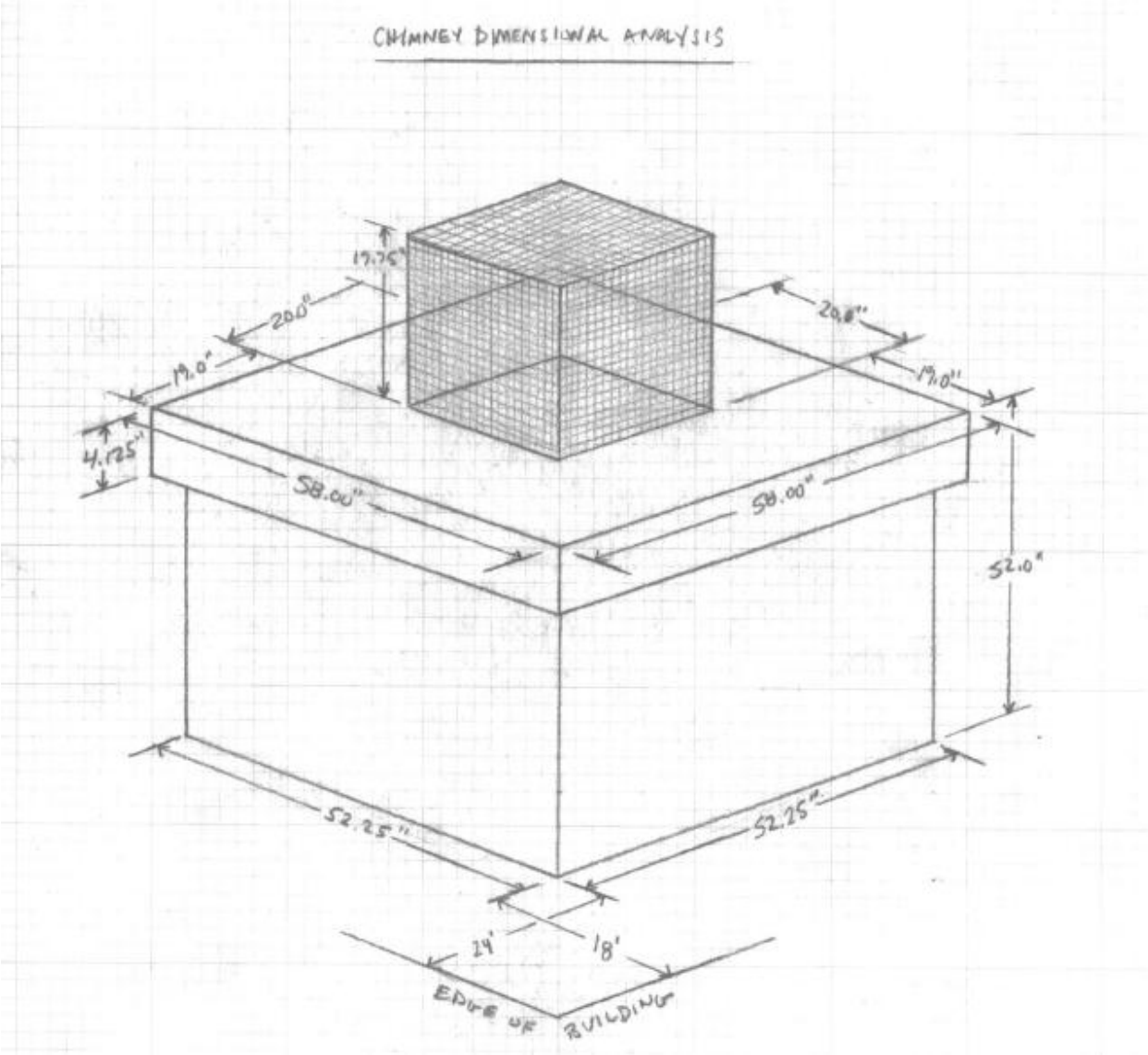

## 12.2. Appendix B: Tower Design

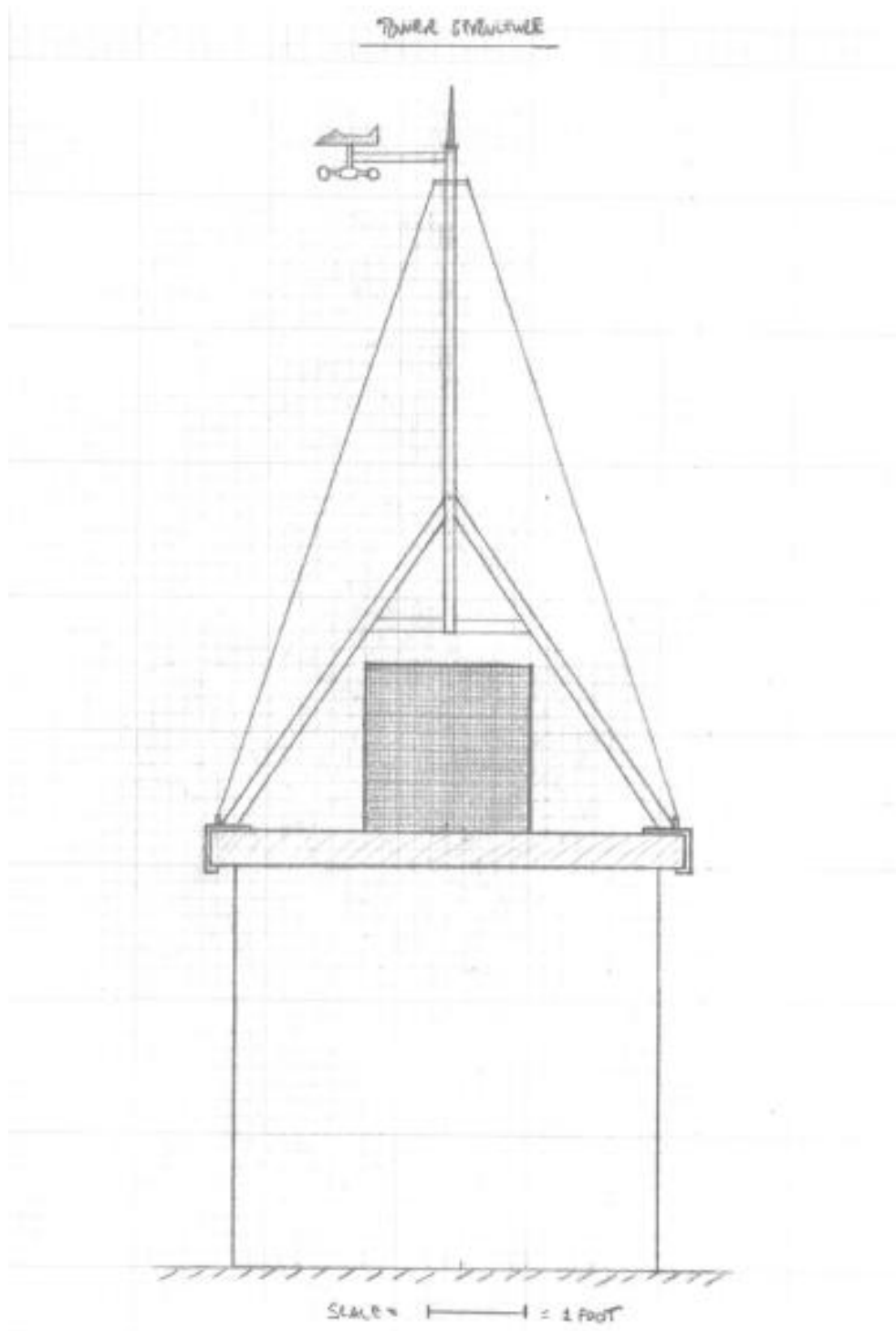

## 12.3. Appendix C: Weather Wizard III Data Sheet

### Weather Wizard III® Station



7425  
7425CS

The Weather Wizard III station features the following: anemometer, inside and outside temperature sensors, junction box, and console. The console provides A/D conversion, calculations, and data display. A DC-power adapter and an 8' (2.4m) cable (for connecting the junction box and console) are included. Options include the Rain Collector, and the WeatherLink which provides data logging and a serial interface to a computer.

#### General

Operating Temperature .....	-5° to 140° F (-20° to 60° C)
Display Temperature .....	32° to 140° F (0° to 60° C)
Supply Power (adapter included) .....	16 mA (typical) at 10 to 16 V (100 mA when display is illuminated)
Connectors .....	Modular (RJ-11, RJ-12, and RJ-45)
Recommended Maximum Cable Length .....	240' (72 m), sensor array to console
Housing Material .....	Black ABS plastic
Display Type .....	LCD
Dimensions	
Console .....	5.25" x 5.4" x 3.0" (133 mm x 137 mm x 76 mm)
Display .....	4.4" x 1.5" (112 mm x 48 mm)
Weight, total .....	3 lbs. 6 oz. (1.53 kg)

#### Sensor Inputs

RF Filtering .....	RC low-pass filter on each signal line
--------------------	--

#### Data Displayed on Console

##### General

Update Interval .....	16 seconds
Times and Dates of Maximum and Minimum Values .....	Stored with value

##### Temperature

Outside Temperature (Air)	
Resolution and Units .....	0.1°F or 0.1°C (user-selectable)
Range .....	-50° to 140° F (-45° to 60° C)
Accuracy .....	±1°F (±0.5°C)
Functions .....	Current Temperature (high and low alarms), Maximum and Minimum Temperatures
Inside Temperature (Air) (sensor located inside console)	
Resolution and Units .....	0.1°F or 0.1°C (user-selectable)
Range .....	32° to 140° F (0° to 60° C)
Accuracy .....	±1°F (±0.5°C)
Functions .....	Current Temperature (high and low alarms), Maximum and Minimum Temperatures

##### Wind

Wind Chill	
Resolution and Units .....	1°F or 1°C (user-selectable)
Range .....	-13.4° to 59° F (-12° to 3.7° C)
Accuracy .....	±4°F (±2°C)
Functions .....	Current Wind Chill (alarm), Minimum Wind Chill

**DAVIS** INSTRUMENTS **Davis Instruments** 3465 Diablo Ave., Hayward, CA 94545-2778  
(510) 732-0229 • FAX (510) 671-0590 • sales@davisnet.com • www.davisnet.com  
DS7425-00 (Rev. D, 1/8/06)

<b>Wind Direction</b>	
Display Resolution .....	16 points (22.5°) on compass rose, 1° in digital display
Accuracy .....	±3°
<b>Wind Speed</b>	
Resolution and Units .....	1 mph, 1 km/hr, 0.1 m/s, or 1 knot (user-selectable)
Range (large wind cups) .....	2 to 150 mph, 2 to 130 knots, 1 to 67 m/s, 2 to 241 km/h
Range (small wind cups) .....	3 to 175 mph, 3 to 150 knots, 1.5 to 78 m/s, 5 to 292 km/h
Update Interval .....	2.25 seconds
Accuracy (large wind cups) .....	±2 mph (2 kts, 3 km/h, 1 m/s) or ±5%, whichever is greater
Accuracy (small wind cups) .....	±3 mph (3 kts, 5 km/h, 1.5 m/s) or ±5%, whichever is greater
Functions .....	Current Speed (alarm), Maximum Speed

**Rainfall (requires Rain Collector)**

Resolution and Units .....	0.01" or 0.2 mm (user-selectable)
Daily Rainfall Range .....	0 to 40.95" (0 to 919 mm)
Total Rainfall Range .....	0 to 99.99" (0 to 9999 mm)
Rainfall Accuracy .....	±5% + 1 count for rates from 0.01" to 2" (0.2 mm to 50 mm) per hour ±5% + 1 count for rates from 2" to 4" (50 mm to 100 mm) per hour
Functions (Period is selected by user) .....	Total Rainfall for period, Daily Rainfall Amount (alarm)

**Time**

Accuracy .....	±15 seconds/month
Functions .....	Current Time, Current Date

**Package Dimensions**

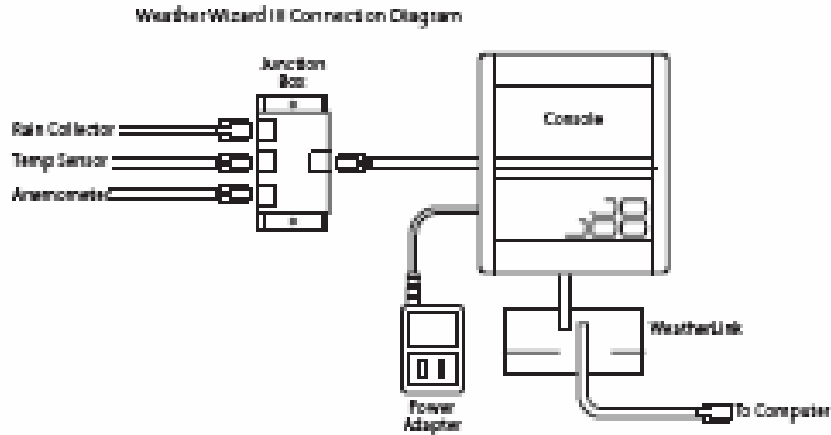

Product #	Package Dimensions (Length x Width x Height)	Package Weight	UPC Codes
7425	16.00" x 10.25" x 5.38" (458 mm x 261 mm x 374 mm)	4.3 lbs. (1.93 kg)	011698 74250 9
7425EU			011698 74251 8
7425UK			011698 74252 3
7425CS	17.50" x 11.75" x 9.25" (458 mm x 299 mm x 335 mm)	8.0 lbs. (3.63 kg)	011698 00594 4
7425CSU			011698 00594 4
7425CSUK			011698 00594 4

**Station Connection Diagram**

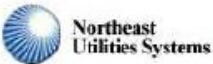

**12.4. Appendix D: Published Wind Data and Wind Rose by AWS TrueWind**

## The New England Wind Map



**Data Sheet:**

Latitude:	42:14:24	Longitude:	-71:46:48	Elevation:	173m.	( 568 ) ft.
decimal:	42.24	decimal:	-71.78	Roughness:	0.3m.	
UTM Coordinates: 269900 x 4680100						

Wind by Time and Height				
	Avg. Wind Speed (m/s)	Avg. Wind Power Density (W/m <sup>2</sup> )	Weibull Parameters	
			c	k
30m Annual	5.2			
<b>50m Annual</b>	5.7	198	6.4	2.16
70m Annual	6.1			
100m Annual	6.5			
50m Spring	6	209	6.8	2.8
50m Summer	4.7	101	5.1	2.22
50m Fall	5.5	185	6.2	2.15
50m Winter	6.6	297	7.4	2.28

### Wind Rose Graph

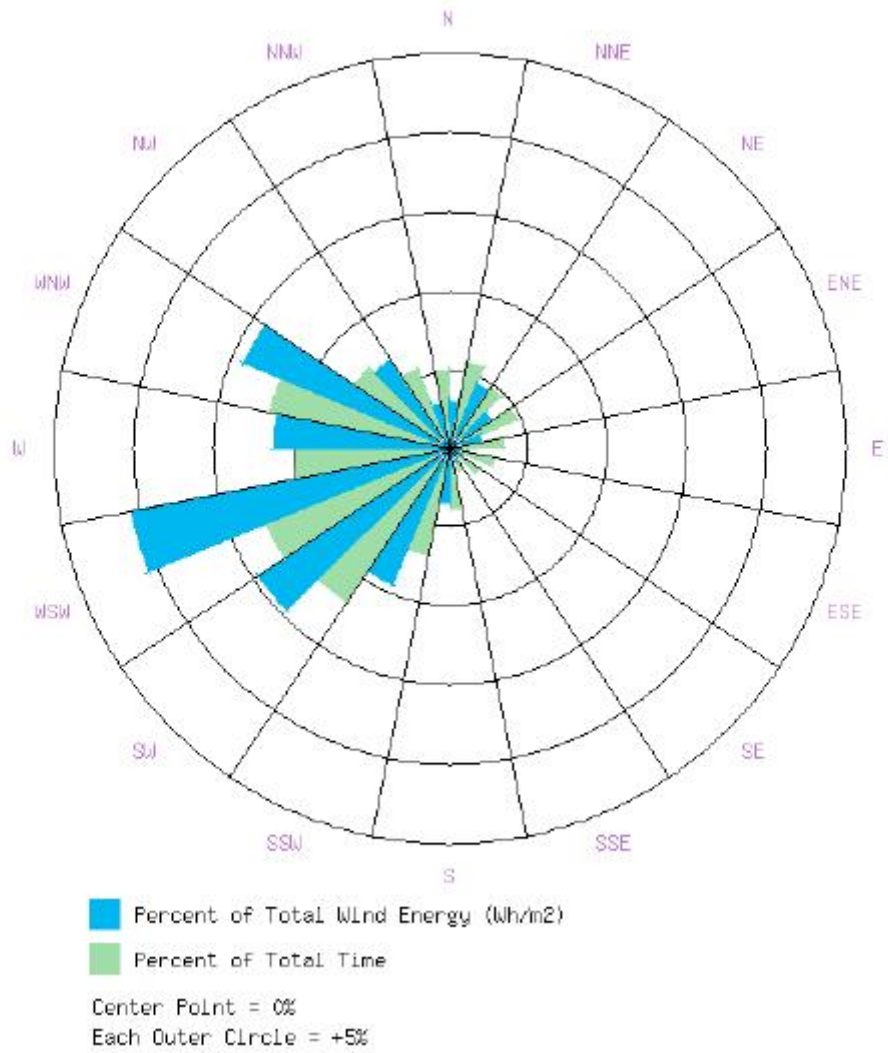

**12.5. Appendix E: Holy Name High School Property Topographical Map**





## 12.6. Appendix F: Wind Turbine Spec Sheets



Us Wind Power Solutions & You Home Refresh Mail

Wind Turbines ▾ 950 kW ▾ Technical Data

Search

**950 kW**

System Design  
 Technical Description  
 Salient Features  
 Technical Data  
 Power Curve

Operating Data	
Rotor diameter	64 m
Hub height	65 m standard (variable as per requirements)
Installed elec. output	950 kW
Cut-in wind speed	3 m/s
Rated wind speed	11 m/s
Cut-out wind speed	25 m/s
Survival wind speed	67 m/s

Rotor	
Blade	3 bladed, horizontal axis
Swept area	3218 m <sup>2</sup>
Rotational Speed	13.9 / 20.8 rpm
Rotor material	Glass fibre reinforced plastic
Regulation	Pitch - regulated

Generator	
Type	Asynchronous generator, 4/6 pole
Rated output	250 / 950 kW
Rotational speed	1208 / 1810 rpm
Frequency	60 Hz

Gearbox	
Type	3 stage (1 planetary & 2 helical)
Ratio	89,229 : 1
Type of cooling	Oil cooling system

<b>Yaw System</b>	
Drive	4 electrical driven planetary gearbox
Bearings	Polyamide slide bearings

<b>Braking System</b>	
Aerodynamic brake	3 independent systems with blade pitching
Mechanical brake	Hydraulic fail safe disc brake system

<b>Control Unit</b>	
Type	Programmable microprocessor-based; high speed data communication, active multilevel security, sophisticated operating software, advance data collection remote monitoring and control option, UPS backup, real-time operation indication

<b>Tower</b>	
Type	Tubular, Epoxy / PU coated

<b>Erection</b>	
Type	With crane

*Note : Technical specifications subject to change without prior notice*

**MID-SIZED WIND TURBINE  
for wind farms,  
distributed generation,  
and wind-diesel applications**



# FL 600



<b>ROTOR</b>	
diameter	43 - 50 m
area	1452 - 1963 sq m
number of blades	3
speed	23 rpm
power regulation	pitch regulated
<b>GEAR BOX</b>	
type	combined spur / planetary gears
stages	3
ratio	1 : 75
<b>GENERATOR</b>	
type	asynchronous, 3 phase
speed	1800 rpm (60 Hertz)
voltage	690 VAC
<b>POWER CHARACTER</b>	
rated output	600 kW
cut in	3 m/s
rated output at	10.8 m/s
cut out	20 m/s
survival wind speed	50 m/s
<b>TOWER</b>	
hub height	50 / 75 m
type	tubular tower
<b>WEIGHT</b>	
rotor	11,600 kg
nacelle	23,000 kg
tower	37,000 / 103,000 kg (50 / 75 m)
<b>CONTROL SYSTEM</b>	
speed regulation	grid connected
yawing control	3 electric yaw motors
main brake	individual blade pitch control
second brake system	disc brake
monitoring	remote data and control
<b>SOUND</b>	
noise level	98 dB(A) at hub, 45 dB(A) at 100m
tonality	none
pulsation	none

The Fuhrländer FL 600 offers advanced technology in a mid-sized wind power platform. Especially suited for displacing high cost utility power at manufacturing, educational, municipal water treatment, and agricultural facilities, the FL 600 can also be used to reduce power costs at large remote (off-grid) diesel generation stations. Features include a variable pitch rotor, an innovative drive train with noise isolation integrated into the supporting structure, and a sophisticated wind turbine controller with a state of the art communications capability. The FL 600 is available with various rotor sizes to insure the best match with the local wind resource. For more information on these elegant machines please contact us at our sales office below.

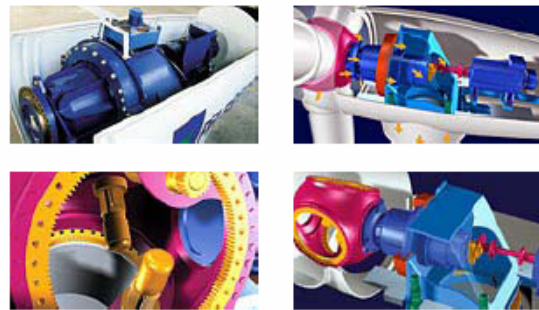

**Lorax Energy Systems, LLC - North American Distributor for Fuhrländer Wind Turbines**

Sales Office: 4 Airport Road, Block Island, RI 02807 Phone: (401) 466-2883 Fax: (401) 466-2909

Corporate Office: 1659 State St, Webster, NY 14580 Phone: (585) 265-6690 Fax: (585) 265-1306

Email: sales@lorax-energy.com Web: www.lorax-energy.com

Site Evaluation • Wind Turbine Sales • Installation • Monitoring • Maintenance

**MID-SIZED WIND TURBINE  
for distributed generation  
or wind-diesel applications**



**FL 250**



The Fuhrländer FL 250 offers exceptional features and value for a mid sized wind turbine. Especially suited for displacing high cost utility power at manufacturing, educational, municipal water treatment, and agricultural facilities, the FL 250 can also be used to reduce power costs at remote (off-grid) diesel generation stations. Features include a two-speed generator with dual electrical windings, aerodynamic blade tip brakes, and a sophisticated wind turbine controller with a state of the art communications capability. Currently installed in many parts of the world, the Fuhrländer FL 250 is a proven leader in its class.

Lorax Energy Systems, LLC is the North American Distributor for Fuhrländer Wind Turbines. For more information on these elegant machines, please contact our sales office.

<b>ROTOR</b>	
diameter	29,5 m
area	706 sq m
number of blades	3
speed	29 / 38 rpm
power regulation	stall regulated
<b>GEAR BOX</b>	
type	combined
stages	3
ratio	1 : 31
<b>GENERATOR</b>	
type	asynchronous, 3 phase
speed	900 - 1200 rpm (60 Hertz)
voltage	480 VAC
<b>POWER CHARACTER</b>	
rated output	250 kW (max. 300 kW)
cut in	2.5 m/s
rated output at	15 m/s
cut out	25 m/s
survival wind speed	55 m/s
<b>TOWER</b>	
hub height	42 / 50 m
type	tubular tower
<b>WEIGHT</b>	
rotor	4,900 kg
nacelle	9,800 kg
tower	26,500 kg (42 m)
<b>CONTROL SYSTEM</b>	
speed regulation	grid connected
yawing control	electric yaw motor
main brake	tip brake
second brake system	disc brake
monitoring	remote data and control
<b>SOUND</b>	
noise level	98 dB(A) at nacelle
tonality	none
pulsation	none

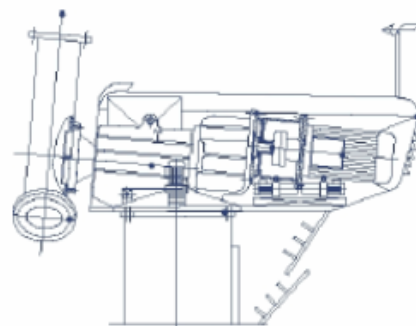

**Lorax Energy Systems, LLC --- Fuhrländer Wind Turbines**

Sales Office: 4 Airport Road, Block Island, RI 02807 Phone: (401) 466-2883 Fax: (401) 466-2909  
 Corporate Office: 1659 State St, Webster, NY 14580 Phone: (585) 265-6690 Fax: (585) 265-1306  
 Email: sales@lorax-energy.com Web: www.lorax-energy.com

**Site Evaluation • Wind Turbine Sales • Installation • Monitoring • Maintenance**

## V52-850 kW - the turbine that goes anywhere



The highly reliable V52-850 kW wind turbine is our offer in the kilowatt class. This all-round turbine is ideal for populated and remote areas alike, with compact dimensions that make it easy to transport overland. The V52 uses pitch technology to optimise the output under medium to high wind conditions. The V52 is available in a wide range of tower heights from 40-86 m.

[Click here to download the V52-850 kW brochure.](#)

### Technical specifications

\* Vestas OptiSpeed™ is not available in the USA or Canada.

#### Rotor

Diameter:	52 m
Swept area:	2,124 m <sup>2</sup>
Speed revolution:	26 rpm
Operational interval:	14.0 - 31.4 rpm
Number of blades:	3
Power regulation:	Pitch/OptiSpeed®
Air brake:	Full blade pitch

#### Tower

Hub height (approx.):	40 - 44 - 49 - 55 - 60 - 65 - 74 - 86 m
-----------------------	---

#### Operational data

Cut-in wind speed:	4 m/s
Nominal wind speed:	16 m/s
Stop wind speed:	25 m/s

#### Generator

Type:	Asynchronous with OptiSpeed®
Nominal output:	850 kW
Operational data:	50/60 Hz 690 V

#### Gearbox

Type:	1 planet step/2-step parallel axle gears
-------	--

#### Control

Type: Microprocessor - based monitoring of all turbine functions as well as OptiSpeed® output regulation and OptiTip® pitch regulation of the blades,

**Weight**

Nacelle 22 t  
 Rotor 10 t

Towers	IEC IA	IEC IIA	DIBt II	DIBt III
Hub height:				
40 m	40 t	-	-	-
44 m	45 t	-	-	-
49 m	50 t	-	-	-
55 m	55 t	50 t	-	-
60 m	70 t	70 t	-	70 t
65 m	75 t	75 t	-	75 t
74 m	-	-	95 t	-
86 m	-	-	110 t	-

*t=metric tonnes*

DIBt towers are only approved for Germany.

All specifications subject to change without notice.

## 12.7. Appendix G: Monthly Weibull Distribution from Holy Name High School

		<b>January</b>			
		<b>Outputs:</b>			
<b>Inputs:</b>	Average Wind Speed (m/s)	6.6 Total Monthly Output (kWh)	138,755		
Weibull K	2.28				
Site Altitude (m)	173				
Turbulence Factor	10%				
Air Density Factor	-1.59%				
Days in Month	31				
<b>Wind Speed (m/s)</b>	<b>Power Output (kW)</b>	<b>Turbine Rated Output (kW)</b>	<b>Wind Probability</b>	<b>Net kW</b>	<b>Monthly Avg Output kWh</b>
1.0	0.00	0.00	2.341%	0.00	0
2.0	0.00	0.00	5.463%	0.00	0
3.0	6.86	7.75	8.502%	0.58	434
4.0	23.42	26.44	10.922%	2.56	1,903
5.0	53.90	60.85	12.356%	6.66	4,954
6.0	102.56	115.80	12.650%	12.97	9,653
7.0	168.20	189.91	11.884%	19.99	14,872
8.0	256.51	289.61	10.320%	26.47	19,694
9.0	363.72	410.65	8.320%	30.26	22,513
10.0	459.54	518.84	6.242%	28.68	21,340
11.0	525.92	593.79	4.364%	22.95	17,075
12.0	539.70	609.34	2.845%	15.35	11,423
13.0	544.94	615.26	1.730%	9.43	7,014
14.0	544.94	615.26	0.981%	5.35	3,978
15.0	544.94	615.26	0.519%	2.83	2,104
16.0	544.94	615.26	0.256%	1.39	1,037
17.0	544.94	615.26	0.117%	0.64	476
18.0	544.94	615.26	0.050%	0.27	204
19.0	544.94	615.26	0.020%	0.11	81
20.0	0.00	0.00	0.007%	0.00	0
21.0	0.00	0.00	0.003%	0.00	0
22.0	0.00	0.00	0.001%	0.00	0
23.0	0.00	0.00	0.000%	0.00	0
24.0	0.00	0.00	0.000%	0.00	0
25.0	0.00	0.00	0.000%	0.00	0

		February	
<b>Inputs:</b>		<b>Outputs:</b>	
Average Wind Speed (m/s)		6.6 Total Monthly Output (kWh)	125,327
Weibull K		2.28	
Site Altitude (m)		173	
Turbulence Factor		10%	
Air Density Factor		-1.59%	
Days in Month		28	
Wind Speed (m/s)	Power Output (kW)	Turbine Rated Output (kW)	Wind Probability
1.0	0.00	0.00	2.341%
2.0	0.00	0.00	5.463%
3.0	6.86	7.75	8.502%
4.0	23.42	26.44	10.922%
5.0	53.90	60.85	12.356%
6.0	102.56	115.80	12.650%
7.0	168.20	189.91	11.884%
8.0	256.51	289.61	10.320%
9.0	363.72	410.65	8.320%
10.0	459.54	518.84	6.242%
11.0	525.92	593.79	4.364%
12.0	539.70	609.34	2.845%
13.0	544.94	615.26	1.730%
14.0	544.94	615.26	0.981%
15.0	544.94	615.26	0.519%
16.0	544.94	615.26	0.256%
17.0	544.94	615.26	0.117%
18.0	544.94	615.26	0.050%
19.0	544.94	615.26	0.020%
20.0	0.00	0.00	0.007%
21.0	0.00	0.00	0.003%
22.0	0.00	0.00	0.001%
23.0	0.00	0.00	0.000%
24.0	0.00	0.00	0.000%
25.0	0.00	0.00	0.000%
Net kW	Monthly Avg Output kWh	Net kW	Monthly Avg Output kWh
0.00	0	0.00	0
0.00	0	0.00	0
0.58	392	0.58	392
2.56	1,719	2.56	1,719
6.66	4,475	6.66	4,475
12.97	8,719	12.97	8,719
19.99	13,432	19.99	13,432
26.47	17,789	26.47	17,789
30.26	20,334	30.26	20,334
28.68	19,275	28.68	19,275
22.95	15,422	22.95	15,422
15.35	10,318	15.35	10,318
9.43	6,335	9.43	6,335
5.35	3,593	5.35	3,593
2.83	1,900	2.83	1,900
1.39	937	1.39	937
0.64	430	0.64	430
0.27	184	0.27	184
0.11	73	0.11	73
0.00	0	0.00	0
0.00	0	0.00	0
0.00	0	0.00	0
0.00	0	0.00	0
0.00	0	0.00	0
0.00	0	0.00	0
0.00	0	0.00	0



<b>Inputs:</b>		<b>Outputs:</b>		<b>March</b>	
Average Wind Speed (m/s)	6	Total Monthly Output (kWh)	107,503		
Weibull K	2.8				
Site Altitude (m)	173				
Turbulence Factor	10%				
Air Density Factor	-1.59%				
Days in Month	31				
<b>Wind Speed (m/s)</b>	<b>Power Output (kW)</b>	<b>Turbine Rated Output (kW)</b>	<b>Wind Probability</b>	<b>Net kW</b>	<b>Monthly Avg Output kWh</b>
1.0	0.00	0.00	1.332%	0.00	0
2.0	0.00	0.00	4.508%	0.00	0
3.0	6.86	7.75	8.719%	0.60	445
4.0	23.42	26.44	12.872%	3.01	2,243
5.0	53.90	60.85	15.728%	8.48	6,307
6.0	102.56	115.80	16.365%	16.78	12,488
7.0	168.20	189.91	14.631%	24.61	18,310
8.0	256.51	289.61	11.243%	28.84	21,457
9.0	363.72	410.65	7.396%	26.90	20,013
10.0	459.54	518.84	4.137%	19.01	14,144
11.0	525.92	593.79	1.952%	10.27	7,639
12.0	539.70	609.34	0.770%	4.16	3,093
13.0	544.94	615.26	0.252%	1.37	1,021
14.0	544.94	615.26	0.067%	0.37	274
15.0	544.94	615.26	0.015%	0.08	60
16.0	544.94	615.26	0.003%	0.01	10
17.0	544.94	615.26	0.000%	0.00	1
18.0	544.94	615.26	0.000%	0.00	0
19.0	544.94	615.26	0.000%	0.00	0
20.0	0.00	0.00	0.000%	0.00	0
21.0	0.00	0.00	0.000%	0.00	0
22.0	0.00	0.00	0.000%	0.00	0
23.0	0.00	0.00	0.000%	0.00	0
24.0	0.00	0.00	0.000%	0.00	0
25.0	0.00	0.00	0.000%	0.00	0

<b>Inputs:</b>		<b>Outputs:</b>		<b>April</b>	
Average Wind Speed (m/s)	6 Total Monthly Output (kWh)	6 Total Monthly Output (kWh)	104,035		
Weibull K	2.8				
Site Altitude (m)	173				
Turbulence Factor	10%				
Air Density Factor	-1.59%				
Days in Month	30				
<b>Wind Speed (m/s)</b>	<b>Power Output (kW)</b>	<b>Turbine Rated Output (kW)</b>	<b>Wind Probability</b>	<b>Net kW</b>	<b>Monthly Avg Output kWh</b>
1.0	0.00	0.00	1.332%	0.00	0
2.0	0.00	0.00	4.508%	0.00	0
3.0	6.86	7.75	8.719%	0.60	431
4.0	23.42	26.44	12.872%	3.01	2,170
5.0	53.90	60.85	15.728%	8.48	6,103
6.0	102.56	115.80	16.365%	16.78	12,085
7.0	168.20	189.91	14.631%	24.61	17,719
8.0	256.51	289.61	11.243%	28.84	20,765
9.0	363.72	410.65	7.396%	26.90	19,367
10.0	459.54	518.84	4.137%	19.01	13,688
11.0	525.92	593.79	1.952%	10.27	7,392
12.0	539.70	609.34	0.770%	4.16	2,993
13.0	544.94	615.26	0.252%	1.37	988
14.0	544.94	615.26	0.067%	0.37	265
15.0	544.94	615.26	0.015%	0.08	58
16.0	544.94	615.26	0.003%	0.01	10
17.0	544.94	615.26	0.000%	0.00	1
18.0	544.94	615.26	0.000%	0.00	0
19.0	544.94	615.26	0.000%	0.00	0
20.0	0.00	0.00	0.000%	0.00	0
21.0	0.00	0.00	0.000%	0.00	0
22.0	0.00	0.00	0.000%	0.00	0
23.0	0.00	0.00	0.000%	0.00	0
24.0	0.00	0.00	0.000%	0.00	0
25.0	0.00	0.00	0.000%	0.00	0

<b>Inputs:</b>		<b>Outputs:</b>		<b>May</b>	
Average Wind Speed (m/s)	6	Total Monthly Output (kWh)	107,503		
Weibull K	2.8				
Site Altitude (m)	173				
Turbulence Factor	10%				
Air Density Factor	-1.59%				
Days in Month	31				
<b>Wind Speed (m/s)</b>	<b>Power Output (kW)</b>	<b>Turbine Rated Output (kW)</b>	<b>Wind Probability</b>	<b>Net kW</b>	<b>Monthly Avg Output kWh</b>
1.0	0.00	0.00	1.332%	0.00	0
2.0	0.00	0.00	4.508%	0.00	0
3.0	6.86	7.75	8.719%	0.60	445
4.0	23.42	26.44	12.872%	3.01	2,243
5.0	53.90	60.85	15.728%	8.48	6,307
6.0	102.56	115.80	16.365%	16.78	12,488
7.0	168.20	189.91	14.631%	24.61	18,310
8.0	256.51	289.61	11.243%	28.84	21,457
9.0	363.72	410.65	7.396%	26.90	20,013
10.0	459.54	518.84	4.137%	19.01	14,144
11.0	525.92	593.79	1.952%	10.27	7,639
12.0	539.70	609.34	0.770%	4.16	3,093
13.0	544.94	615.26	0.252%	1.37	1,021
14.0	544.94	615.26	0.067%	0.37	274
15.0	544.94	615.26	0.015%	0.08	60
16.0	544.94	615.26	0.003%	0.01	10
17.0	544.94	615.26	0.000%	0.00	1
18.0	544.94	615.26	0.000%	0.00	0
19.0	544.94	615.26	0.000%	0.00	0
20.0	0.00	0.00	0.000%	0.00	0
21.0	0.00	0.00	0.000%	0.00	0
22.0	0.00	0.00	0.000%	0.00	0
23.0	0.00	0.00	0.000%	0.00	0
24.0	0.00	0.00	0.000%	0.00	0
25.0	0.00	0.00	0.000%	0.00	0

		June				
		Outputs:	57,798			
		4.7 Total Monthly Output (kWh)				
		2.22				
		173				
		10%				
		-1.59%				
		30				
Inputs:	Wind Speed (m/s)	Power Output (kW)	Turbine Rated Output (kW)	Wind Probability	Net kW	Monthly Avg Output kWh
Average Wind Speed (m/s)	1.0	0.00	0.00	5.384%	0.00	0
Weibull K	2.0	0.00	0.00	11.452%	0.00	0
Site Altitude (m)	3.0	6.86	7.75	15.859%	1.09	784
Turbulence Factor	4.0	23.42	26.44	17.461%	4.09	2,944
Air Density Factor	5.0	53.90	60.85	16.219%	8.74	6,294
Days in Month	6.0	102.56	115.80	13.022%	13.36	9,617
	7.0	168.20	189.91	9.143%	15.38	11,073
	8.0	256.51	289.61	5.645%	14.48	10,426
	9.0	363.72	410.65	3.074%	11.18	8,051
	10.0	459.54	518.84	1.478%	6.79	4,892
	11.0	525.92	593.79	0.628%	3.30	2,378
	12.0	539.70	609.34	0.236%	1.27	916
	13.0	544.94	615.26	0.078%	0.43	306
	14.0	544.94	615.26	0.023%	0.12	89
	15.0	544.94	615.26	0.006%	0.03	23
	16.0	544.94	615.26	0.001%	0.01	5
	17.0	544.94	615.26	0.000%	0.00	1
	18.0	544.94	615.26	0.000%	0.00	0
	19.0	544.94	615.26	0.000%	0.00	0
	20.0	0.00	0.00	0.000%	0.00	0
	21.0	0.00	0.00	0.000%	0.00	0
	22.0	0.00	0.00	0.000%	0.00	0
	23.0	0.00	0.00	0.000%	0.00	0
	24.0	0.00	0.00	0.000%	0.00	0
	25.0	0.00	0.00	0.000%	0.00	0



<b>Inputs:</b>		<b>Outputs:</b>		<b>August</b>	
<b>Average Wind Speed (m/s)</b>	<b>Power Output (kW)</b>	<b>Turbine Rated Output (kW)</b>	<b>Wind Probability</b>	<b>Net kW</b>	<b>Monthly Avg Output kWh</b>
Weibull K	0.00	0.00	5.384%	0.00	0
Site Altitude (m)	0.00	0.00	11.452%	0.00	0
Turbulence Factor	6.86	7.75	15.859%	1.09	810
Air Density Factor	23.42	26.44	17.461%	4.09	3,042
Days in Month	53.90	60.85	16.219%	8.74	6,503
<b>Wind Speed (m/s)</b>	102.56	115.80	13.022%	13.36	9,937
1.0	168.20	189.91	9.143%	15.38	11,442
2.0	256.51	289.61	5.645%	14.48	10,774
3.0	363.72	410.65	3.074%	11.18	8,319
4.0	459.54	518.84	1.478%	6.79	5,055
5.0	525.92	593.79	0.628%	3.30	2,457
6.0	539.70	609.34	0.236%	1.27	946
7.0	544.94	615.26	0.078%	0.43	316
8.0	544.94	615.26	0.023%	0.12	92
9.0	544.94	615.26	0.006%	0.03	24
10.0	544.94	615.26	0.001%	0.01	5
11.0	544.94	615.26	0.000%	0.00	1
12.0	544.94	615.26	0.000%	0.00	0
13.0	544.94	615.26	0.000%	0.00	0
14.0	544.94	615.26	0.000%	0.00	0
15.0	0.00	0.00	0.000%	0.00	0
16.0	0.00	0.00	0.000%	0.00	0
17.0	0.00	0.00	0.000%	0.00	0
18.0	0.00	0.00	0.000%	0.00	0
19.0	0.00	0.00	0.000%	0.00	0
20.0	0.00	0.00	0.000%	0.00	0
21.0	0.00	0.00	0.000%	0.00	0
22.0	0.00	0.00	0.000%	0.00	0
23.0	0.00	0.00	0.000%	0.00	0
24.0	0.00	0.00	0.000%	0.00	0
25.0	0.00	0.00	0.000%	0.00	0

		September				
		Outputs:	90,165			
		5.5 Total Monthly Output (kWh)				
		2.15				
		173				
		10%				
		-1.59%				
		30				
Inputs:	Wind Speed (m/s)	Power Output (kW)	Turbine Rated Output (kW)	Wind Probability	Net kW	Monthly Avg Output kWh
Average Wind Speed (m/s)	1.0	0.00	0.00	4.199%	0.00	0
Weibull K	2.0	0.00	0.00	8.702%	0.00	0
Site Altitude (m)	3.0	6.86	7.75	12.266%	0.84	606
Turbulence Factor	4.0	23.42	26.44	14.248%	3.34	2,402
Air Density Factor	5.0	53.90	60.85	14.463%	7.79	5,612
Days in Month	6.0	102.56	115.80	13.156%	13.49	9,716
	7.0	168.20	189.91	10.863%	18.27	13,156
	8.0	256.51	289.61	8.201%	21.04	15,146
	9.0	363.72	410.65	5.684%	20.67	14,885
	10.0	459.54	518.84	3.627%	16.67	11,999
	11.0	525.92	593.79	2.134%	11.22	8,079
	12.0	539.70	609.34	1.159%	6.25	4,502
	13.0	544.94	615.26	0.581%	3.17	2,280
	14.0	544.94	615.26	0.269%	1.47	1,056
	15.0	544.94	615.26	0.115%	0.63	452
	16.0	544.94	615.26	0.046%	0.25	179
	17.0	544.94	615.26	0.017%	0.09	65
	18.0	544.94	615.26	0.006%	0.03	22
	19.0	544.94	615.26	0.002%	0.01	7
	20.0	0.00	0.00	0.001%	0.00	0
	21.0	0.00	0.00	0.000%	0.00	0
	22.0	0.00	0.00	0.000%	0.00	0
	23.0	0.00	0.00	0.000%	0.00	0
	24.0	0.00	0.00	0.000%	0.00	0
	25.0	0.00	0.00	0.000%	0.00	0

		October				
		Outputs:				
		5.5 Total Monthly Output (kWh)		93,171		
		2.15				
		173				
		10%				
		-1.59%				
		31				
Inputs:		Power Output (kW)	Turbine Rated Output (kW)	Wind Probability	Net kW	Monthly Avg Output kWh
Average Wind Speed (m/s)		0.00	0.00	4.199%	0.00	0
Weibull K		0.00	0.00	8.702%	0.00	0
Site Altitude (m)		6.86	7.75	12.266%	0.84	626
Turbulence Factor		23.42	26.44	14.248%	3.34	2,482
Air Density Factor		53.90	60.85	14.463%	7.79	5,799
Days in Month		102.56	115.80	13.156%	13.49	10,039
Wind Speed (m/s)		168.20	189.91	10.863%	18.27	13,595
1.0		256.51	289.61	8.201%	21.04	15,651
2.0		363.72	410.65	5.684%	20.67	15,381
3.0		459.54	518.84	3.627%	16.67	12,399
4.0		525.92	593.79	2.134%	11.22	8,349
5.0		539.70	609.34	1.159%	6.25	4,652
6.0		544.94	615.26	0.581%	3.17	2,356
7.0		544.94	615.26	0.269%	1.47	1,091
8.0		544.94	615.26	0.115%	0.63	467
9.0		544.94	615.26	0.046%	0.25	185
10.0		544.94	615.26	0.017%	0.09	68
11.0		544.94	615.26	0.006%	0.03	23
12.0		544.94	615.26	0.002%	0.01	7
13.0		0.00	0.00	0.001%	0.00	0
14.0		0.00	0.00	0.000%	0.00	0
15.0		0.00	0.00	0.000%	0.00	0
16.0		0.00	0.00	0.000%	0.00	0
17.0		0.00	0.00	0.000%	0.00	0
18.0		0.00	0.00	0.000%	0.00	0
19.0		0.00	0.00	0.000%	0.00	0
20.0		0.00	0.00	0.000%	0.00	0
21.0		0.00	0.00	0.000%	0.00	0
22.0		0.00	0.00	0.000%	0.00	0
23.0		0.00	0.00	0.000%	0.00	0
24.0		0.00	0.00	0.000%	0.00	0
25.0		0.00	0.00	0.000%	0.00	0



		November				
		Outputs:	90,165			
		5.5 Total Monthly Output (kWh)				
		2.15				
		173				
		10%				
		-1.59%				
		30				
Inputs:	Wind Speed (m/s)	Power Output (kW)	Turbine Rated Output (kW)	Wind Probability	Net kW	Monthly Avg Output kWh
Average Wind Speed (m/s)	1.0	0.00	0.00	4.199%	0.00	0
Weibull K	2.0	0.00	0.00	8.702%	0.00	0
Site Altitude (m)	3.0	6.86	7.75	12.266%	0.84	606
Turbulence Factor	4.0	23.42	26.44	14.248%	3.34	2,402
Air Density Factor	5.0	53.90	60.85	14.463%	7.79	5,612
Days in Month	6.0	102.56	115.80	13.156%	13.49	9,716
	7.0	168.20	189.91	10.863%	18.27	13,156
	8.0	256.51	289.61	8.201%	21.04	15,146
	9.0	363.72	410.65	5.684%	20.67	14,885
	10.0	459.54	518.84	3.627%	16.67	11,999
	11.0	525.92	593.79	2.134%	11.22	8,079
	12.0	539.70	609.34	1.159%	6.25	4,502
	13.0	544.94	615.26	0.581%	3.17	2,280
	14.0	544.94	615.26	0.269%	1.47	1,056
	15.0	544.94	615.26	0.115%	0.63	452
	16.0	544.94	615.26	0.046%	0.25	179
	17.0	544.94	615.26	0.017%	0.09	65
	18.0	544.94	615.26	0.006%	0.03	22
	19.0	544.94	615.26	0.002%	0.01	7
	20.0	0.00	0.00	0.001%	0.00	0
	21.0	0.00	0.00	0.000%	0.00	0
	22.0	0.00	0.00	0.000%	0.00	0
	23.0	0.00	0.00	0.000%	0.00	0
	24.0	0.00	0.00	0.000%	0.00	0
	25.0	0.00	0.00	0.000%	0.00	0

		December				
		Outputs:	138,755			
		6.6 Total Monthly Output (kWh)				
		2.28				
		173				
		10%				
		-1.59%				
		31				
Inputs:	Wind Speed (m/s)	Power Output (kW)	Turbine Rated Output (kW)	Wind Probability	Net kW	Monthly Avg Output kWh
Average Wind Speed (m/s)	1.0	0.00	0.00	2.341%	0.00	0
Weibull K	2.0	0.00	0.00	5.463%	0.00	0
Site Altitude (m)	3.0	6.86	7.75	8.502%	0.58	434
Turbulence Factor	4.0	23.42	26.44	10.922%	2.56	1,903
Air Density Factor	5.0	53.90	60.85	12.356%	6.66	4,954
Days in Month	6.0	102.56	115.80	12.650%	12.97	9,653
Wind Speed (m/s)	7.0	168.20	189.91	11.884%	19.99	14,872
	8.0	256.51	289.61	10.320%	26.47	19,694
	9.0	363.72	410.65	8.320%	30.26	22,513
	10.0	459.54	518.84	6.242%	28.68	21,340
	11.0	525.92	593.79	4.364%	22.95	17,075
	12.0	539.70	609.34	2.845%	15.35	11,423
	13.0	544.94	615.26	1.730%	9.43	7,014
	14.0	544.94	615.26	0.981%	5.35	3,978
	15.0	544.94	615.26	0.519%	2.83	2,104
	16.0	544.94	615.26	0.256%	1.39	1,037
	17.0	544.94	615.26	0.117%	0.64	476
	18.0	544.94	615.26	0.050%	0.27	204
	19.0	544.94	615.26	0.020%	0.11	81
	20.0	0.00	0.00	0.007%	0.00	0
	21.0	0.00	0.00	0.003%	0.00	0
	22.0	0.00	0.00	0.001%	0.00	0
	23.0	0.00	0.00	0.000%	0.00	0
	24.0	0.00	0.00	0.000%	0.00	0
	25.0	0.00	0.00	0.000%	0.00	0